

Digital I/O PMC

Conduction-cooled 3.3/5V Hi Drive Digital Rear I/O PMC

The Technobox, Inc. P/N 9413 High-Drive/Voltage is a VITA 20 conduction-cooled PMC offering 64-bits of digital I/O available at the PN4 connector.

A PLX/Broadcom 9056 bridge chip provides a 32-bit, 33- or 66- MHz PCI interface to a local bus, which is connected to an Altera 5CGXFC4C-6F27I7N FPGA.

The I/O side of the FPGA is handled with 5V-powered 74ABT126 drivers and 5V-powered 74LVC8T245 receivers, which also translate the signals to 3.3V levels for use by the FPGA. The drivers are capable of -32ma IOH and

64ma IOL, making it suitable for VME-level signaling and other older 5V technologies.

The 9413 can also be populated with other 74xxx126 drivers, including those for 3.3V powered devices. If there is a unique requirement, Technobox, Inc. will assign a separate, orderable part number.

Each of the 64 DIO channels has a resistor population option to disconnect the I/O and tie it to ground, or series terminate with a specified resistor. The default deliverable (ie, P/N 9413) has all channels connected to the I/O pin through a zero-ohm resistor.

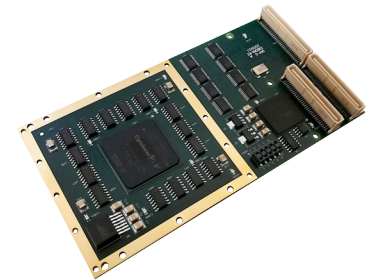

9413

- 64 Bits of High-Drive I/O
64mA sink, 32 mA source
- +3.3V or +5V I/O Voltage
- Conduction-cooled Design
- VITA 20 Thermal Features
- FPGA Design Flexibility
- Technobox Reference Designs Supplied
- Industrial Temperature Design
- Lead-free

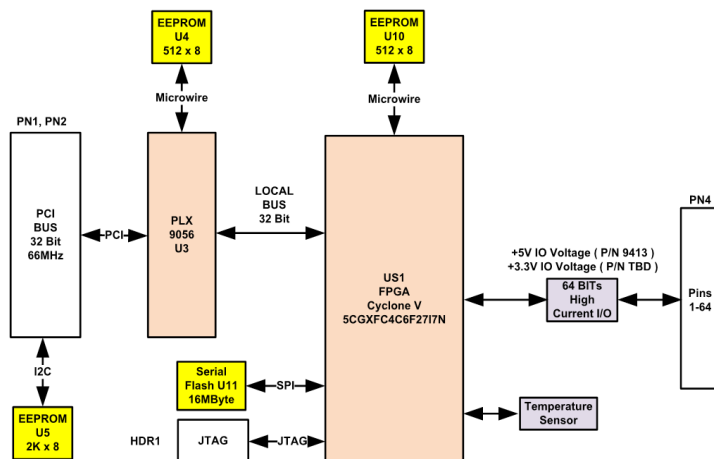

BLOCK DIAGRAM

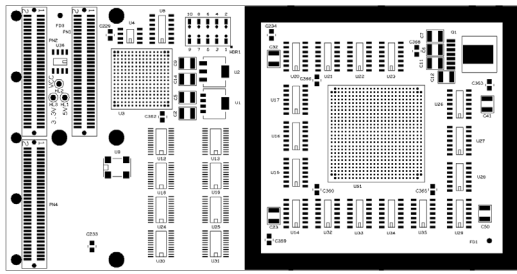

COMPONENT PLACEMENT VIEW - SIDE #1

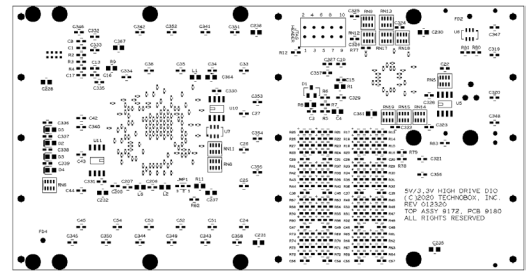

COMPONENT PLACEMENT VIEW - SIDE #2

The FPGA and the associated 128Mb (16MB) FLASH memory that downloads FPGA code during power up can be programmed by a JTAG header located on the 9413 board, using a customer supplied USB Blaster or equivalent. Alternatively, the FLASH memory can be programmed

over the PCI bus if the IP exists in the initialized FPGA to support this mode.

The design also features a temperature sensor and EEPROM for customer parameters, if needed, connected to the FPGA.

9413 uses all Industrial Temperature Range (I-temp -40 to +85 Deg C) parts and is built with RoHS solder and components.

SPECIFICATIONS

Temperature (Operating): -40 to +85 degrees C

Temperature (Storage): -55 to +105 degrees C

Altitude: Not specified or characterized. Typical similar equipment is at 15,000 ft.

Humidity (Operating/Storage): 5% to 95% non-condensing.

Vibration: Not specified or characterized

Shock: Not specified or characterized

MTBF: Available upon request

Weight: 66 grams

Voltages Required: +3.3V, +5.0V, VIO

Power: 0.34 Amps on +3.3V, 0.23 Amps on +5V with +5V IO Drivers

Size: 74mm x 143.7mm

ORDERING INFORMATION

9413: Conduction Cooled 3.3/5V Hi Drive Digital Rear I/O PMC

