

# PMC Carrier/Adapter

## PMC-to-PCI Adapter - For Test

The PMC-to-PCI Adapter for Test is an active extender that accommodates live insertion of one PCI Mezzanine Card (PMC) for performance analysis and testing in a PCI bus environment. When mounted, both sides of the PMC under test are readily accessible. The adapter may be used for both development and production testing. In production applications, use a Technobox PMC Socket Saver (P/N 2283) to preserve the adapter's PMC connectors.

Both 32- and 64-bit PCI bus systems are supported. The adapter's edge-finger connector is universally keyed for 3.3- and 5-volt signaling. Furthermore, the keying pegs have been removed so that PMCs with either 3.3- or 5-volt signaling can be mounted. Since the standard PCI bus does not support the PMCBUSMODE[4...1] signals, a DIP switch located on the adapter is used to set up BUSMODE[4..2] to properly drive the PMC card. A dedicated LED

indicates a BUSMODE[1] response by the PMC. A pair of JTAG connectors provides access to on-board PLDs for programming.

For diagnostics, the adapter features 96 analyzer channels (32 control, 64 address). Six 20-pin headers afford attachment of protocol analyzer termination adapters. The headers are compatible with Hewlett Packard analyzers using 20-to-40 pin Termination Adapters. Four spare analyzer channels appear at a separate 4-position, single-row header.

PN4 signals are routed to two 96-pin "inverse" DIN connectors to emulate connection of rear I/O to the 'A' and 'C' rows of the P2 connector on a VME bus board. The DIN connectors are wired in parallel, allowing simultaneous connection of a device and a piece of test equipment. To assure signal integrity, the adapter is designed with 4 power planes and clamping diodes for

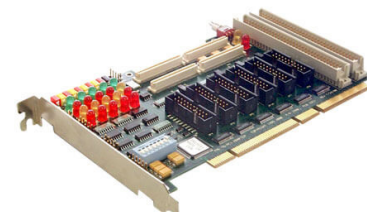

## 3390

- PMC Live Insertion
- PMC Power Switch
- Allows Access to Both Sides of the PMC
- Logic Analyzer Headers
- Right Angle PMC Mounting
- RoHS-compatible
- Lead-free

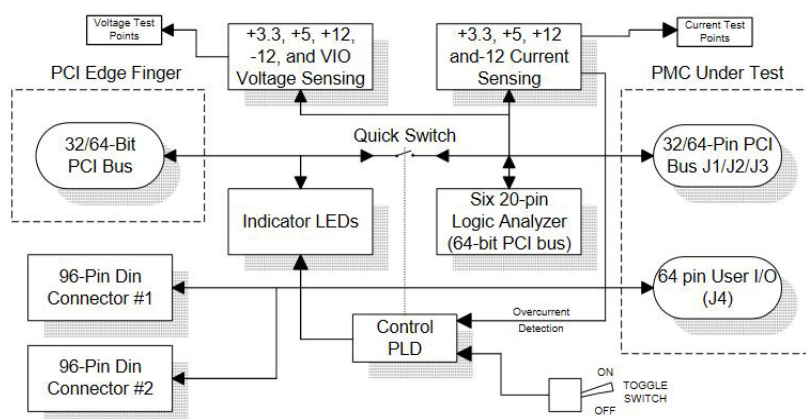

**Technobox<sup>®</sup>, inc.**

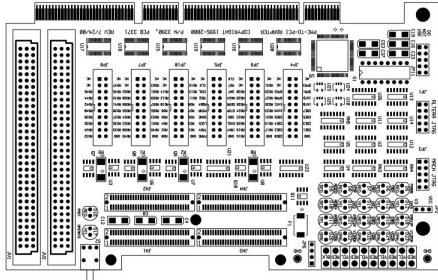

## COMPONENT PLACEMENT VIEW - SIDE #1

key PCI signals. The adapter minimizes wear and tear on the testplatform system due to repetitious power cycling and-system rebooting. Power to the PMC under test canbe toggled using an ON/OFF switch that is mounted on the top edge of the adapter. This eliminates poweringthe platform system on and off whenever a PMC is installed or removed.

Soft-start sequencing and special circuits, including CMOS-based, zero propagation Quick

Switches,protect against voltage and current transients and assure that the PMC is effectively isolated from the PCI bus during power on/off sequencing. These circuits prevent system crashes or hanging up the PCI bus when applying power.

Assorted LEDs provide immediate status of power,current conditions, and activity for key PCI bus signals.The LEDs can be especially helpful when trouble shooting; e.g., when dealing with a hung bus condition.

A bank of 10 test points, situated at the top edge of the adapter, affords access to VIO, +3.3V, +5V, +12V,and -12V power and provides a convenient ground foran oscilloscope probe. Test points are also provided to allow current measurements using a voltmeter.

A current-to-voltage converter provides a direct reading of current as a voltage level, with 1 volt corresponding to 1 amp.

### SPECIFICATIONS

Typical Power Dissipation: N/A

Power Supplies Required: Per PMC Under Test

PCI Signaling Environment: 3.3 Volt, 5 Volt

### ORDERING INFORMATION

**3390:** PMC-to-PCI Adapter - For Test

# Technobox<sup>®</sup>, inc.

Technobox, Inc.

154 Cooper Road, Suite 901

West Berlin, NJ 08091

Phone: 856-809-2306 • Fax: 856-809-2601

Email: sales@technobox.com

Website: www.technobox.com