

Storage Controller XMC

U.2 to XMC Adapter

The Technobox U.2 to XMC adapter permits operation of a PCI Express (PCIe) based "U.2" 2.5 Inch Solid State Disk (SSD) in an XMC site.

The product is offered in two styles: an IEEE 1386.1 air-cooled version (P/N 8377), and a VITA20 conduction cooled version (P/N 8376).

The air-cooled version includes a front panel bezel, through which an activity LED is visible. The adapter has a sizable opening below the SSD to allow for efficient cooling.

The conduction-cooled version incorporates a substantial black-anodized aluminum heatsink which thermally couples the bottom of the SSD to a VITA 20 compliant heatframe. The adapter is secured to the center rail and end rail for ample thermal conductivity, keeping in mind an SSD might dissipate considerable power on the order of 10 to 20 watts when transferring data. An activity LED is visible on the adapter.

The SSD, exemplified by a Micron PCIe 9100 Series SSD, is typically 15mm thick. This precludes the use of the SSD within the confines of an XMC component envelope. Assuming a 1.6mm thick Printed Circuit Board (PCB), the IEEE 1386 standard allows a 1.9mm high component on the secondary side of the board. A 15mm thick SSD will, therefore, exceed the allowed component height by 13.1mm. For this adapter, the SSD is seated on the back side ("Side 2") of the XMC. The SSD is likely to project into the adjacent space which might normally be occupied by another board. Users will need to evaluate if their application can tolerate the additional height requirement.

The adapter has an appreciable on-board DC to DC converter which uses the XMC VPWR rail to generate +12V to power the SSD. Operation of VPWR at either +5V or +12V is supported. The circuit design will automatically sense and switch to accommodate either voltage. Up to 25 watts of +12V power is available to the SSD.



Typical installation shown.
SSD media not included

8377
.....

- Supports 2.5 inch SSD per U.2 standard
- Four (4) PCI Express lanes
- PCI express Gen 1, 2, 3 speeds
- XMC Air-cooled form factor (P/N 8377)
- VITA 61 versions available
- Substantial opening for air cooling SSD
- VITA 20 XMC Conduction Cooled form factor (P/N 8376)
- Conduction Cooled heat sink
- VPWR at either 5V or 12V automatically sensed
- Supplies up to 25 watts +12V SSD power from VPWR rail
- IPMI serial EEPROM
- Optionally bundled with SSD
- RoHS, Industrial Temperature Range components
- LED indicates drive activity
- Thermal features to aid with power dissipation on high power U.2 devices
- ROHS complaint
- Industrial temp

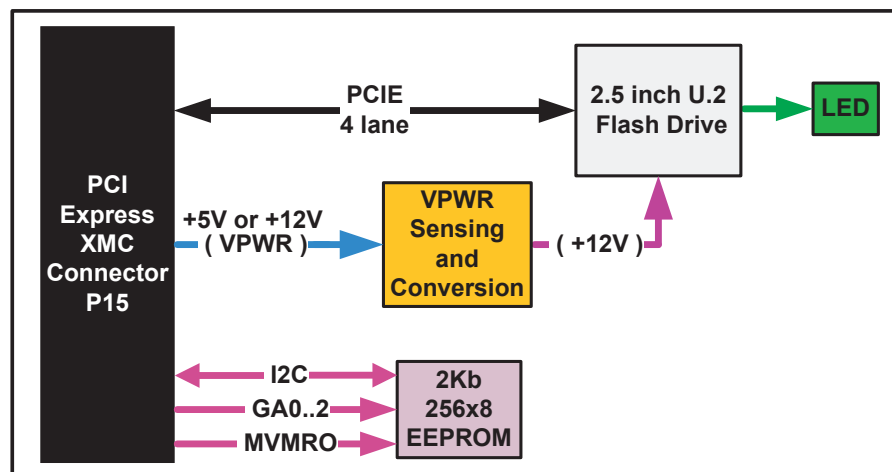

Technobox

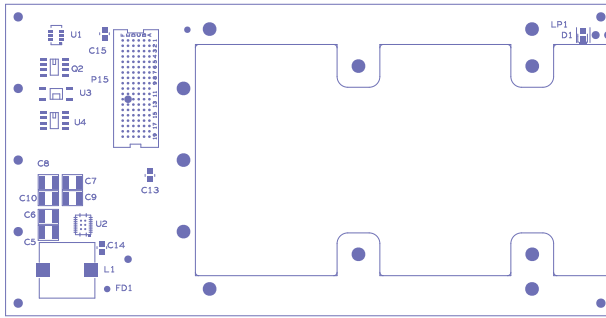

Component Placement View - Side 1

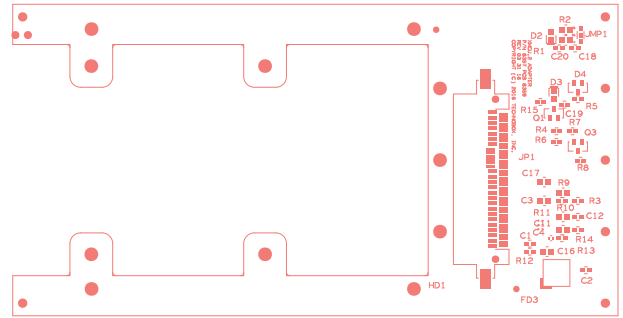

Component Placement View - Side 2

The adapter supports the maximum of four PCIe lanes allowed by the U.2 standard. Gen 1,2, and 3 speeds have been demonstrated using the Micron PCIe 9100 Series SSD or equivalent. Operation with host connectivity of less than four lanes is allowed, but with reduced performance.

An on-board EEPROM supports IPMI data as required by the VITA42 standard.

When ordering P/N 8377 or 8376 (VITA 42 connectors), the unit is supplied without an SSD. It is expected that customers will procure their own SSD. For customers who might prefer a bundled solution, Technobox will procure and integrate an

SSD and assign a unique orderable P/N for those configurations. All adapters are functionally tested with the Micron PCIe 9100 Series SSD or equivalent.

For those who require VITA61 connectivity, the product is also available with VITA 61 connectors.

Specifications

- Temperature (Operating):** -40 to +85 degrees C (board only, without drive)
- Temperature (Storage):** -40 to +105 degrees C
- Altitude:** Not Specified or Characterized. Typical similar equip. is at 15,000 ft.
- Humidity (Operating/Storage):** 5% to 95% non-condensing.
- Vibration:** Not specified or Characterized.
- Shock:** Not specified or Characterized.
- MTBF:** Available on request.
- Weight:** 45 grams without drive or heatsink.
- Weight:** 115 grams with heatsink.
- Weight:** 230 grams with drive and heatsink.
- Power:** TBD, mostly dependent on chosen U.2 drive.
- PCI express:** 4 lane, Gen 3,2,1 dependent on drive mounted.
- Voltages Required XMC:** +3.3Vaux, VPWR (+12V or +5V)
- Voltages Available Drive:** +3.3Vaux, +12V
- Size** 74 mm x 152.5 mm air cooled
- Size** 74 mm x 143.8 mm conduction cooled
- PCB Thickness** 1.74mm / 0.069" +/-10% as per standard PCBs

Ordering Information

- 8377:** U.2 Adapter for air-cooled XMC. Allows U.2 SSD, such as the Micron PCIe 9100 Series 2.5" drive, to operate in an XMC site. SSD mounts to back of XMC and might require extra adjacent space. Includes front panel activity LED. SSD not included.
- 8376:** U.2 Adapter for Conduction Cooled XMC. Allows U.2 SSD, such as the Micron PCIe 9100 Series 2.5" drive, to operate in an VITA 20 site. SSD mounts to back of XMC and might require extra adjacent space. Includes heatsink. SSD not included.
- 8475:** U.2 Adapter for air-cooled XMC. Allows U.2 SSD, such as the Micron PCIe 9100 Series 2.5" drive, to operate in an XMC site. SSD mounts to back of XMC and might require extra adjacent space. Includes front panel activity LED. SSD not included. VITA 61 connectors
- 8474:** U.2 Adapter for Conduction Cooled XMC. Allows U.2 SSD, such as the Micron PCIe 9100 Series 2.5" drive, to operate in an VITA 20 site. SSD mounts to back of XMC and might require extra adjacent space. Includes heatsink. SSD not included. VITA 61 connectors

