

# XMC Carrier/Adapter

## Compact XMC to PCI Express Adapter

The Technobox, Inc. P/N 8241 Compact XMC-to-PCI Express (PCIe) adapter permits use of a standard VITA 42.3 air-cooled XMC in the smallest possible edge finger PCIe form factor. The length of the adapter is the length of the XMC, while the height is a standard PCIe board, not the low-profile version. It provides up to eight lanes (8X) from the XMC's P15 connector to the edge fingers.

PCIe Gen1 (2.5Gb/s), Gen2 (5Gb/s), and Gen3 (8Gb/s) are supported, but should be demonstrated for a customer's specific board complement. Variants of the adapter are available to support 4X (P/N 8366) and 1X (P/N 8367) lanes. All variants can be built with VITA 61 style (XMC 2.0) connectors for enhanced performance.

The front panel of the XMC engages with a machined aluminum opening for the PCIe card bracket, mimicking the mechanical fit in a typical IEEE 1101.10 front-panel as would be

used for VME, Compact PCI, and VPX. To save space and cost, this product does not support P16 rear I/O. Other Technobox adapters are available with rear I/O support.

The adapter's prominent circular opening serves two purposes. When left open, it provides sufficient convection cooling airflow for low-power XMCs. For high-power modules, an optional fan assembly (P/N 8254) can be installed by the end-user. The 8254 uses a highly reliable ball bearing blower-style fan with a 50,000 hour MTBF. Normally used for cooling processor, it is rated for a generous 11 cfm airflow and does not stall, as can be the case with pancake fans. Note that the height of the fan is 15 mm off the back side of the adapter and will take up the adjacent slot.

The fan's 4-pin cable can be connected to either a spare fan connector on the motherboard or the 4-pin header on the adapter. An on-board fan controller allows the user to se-

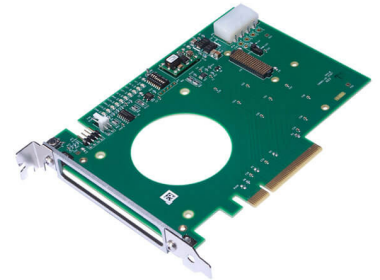

## 8241

- Smallest possible form factor
- Adapts XMC to PCI Express (8X, 4X, and 1X)
- VITA 42 connector standard
- VITA 61 connector available
- Powerful Blower fan option (11 cfm)
- On-board Fan controller
- Fan tach alarm & speed setting
- VPWR either 12V or 5V per jumper/disk connector
- Generates -12V rail to XMC
- Provides +3.3 and +12V from PCIe edge finger
- Status LEDs
- Power LEDs
- DIP switch for geographical address, etc.
- No rear I/O (PN4 or P16) support
- Industrial Temperature
- RoHS Compliant

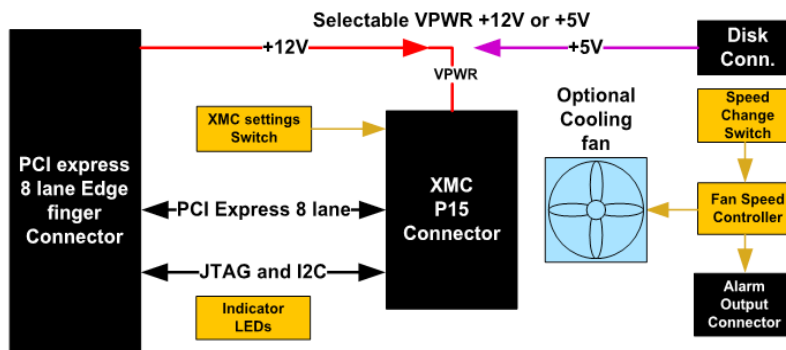

**Technobox<sup>®</sup>, inc.**

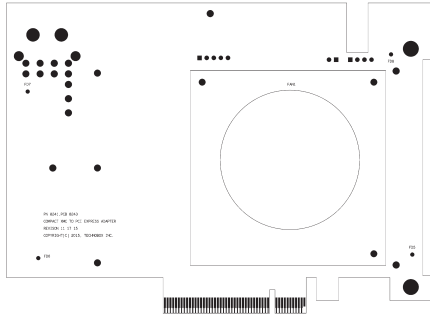

**COMPONENT PLACEMENT VIEW - SIDE #1**

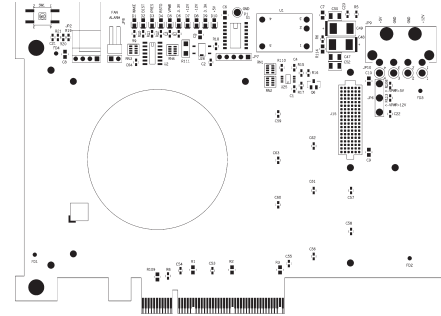

**COMPONENT PLACEMENT VIEW - SIDE #2**

lect one of five speed settings, using a push button situated on the edge of the adapter. Once set, the speed selection is retained in the controller's non-volatile memory. The fan controller provides an optoisolated malfunction "alarm" via a connector at the edge of the board that can be wired to an available system IPMI contact sensor, or other alarm mechanism, if desired.

The installed XMC is provided with +12V and +3.3V directly from the PCIe edge fingers. An on-board

POLA module provides -12V. XMC "VPWR" is set to either +12V or +5V using a jumper on the adapter. Power for the +12V position comes from the edge finger, while +5V is provide by a four-pin Molex disk supply connector that is readily available with most PC power supplies.

Note that a properly designed XMC should work with either voltage, so connection to a disk power connector should not be necessary. DIP switches set various configurations

for the XMC, such as geographical address. LEDs indicate status for available power and XMC status signals (e.g., WAKE and PRESENT).

The adapter is built with industrial temperature range (-40 to +85 Deg C) parts and is RoHS compliant. The optional fan is specified at -10 to +65 Deg C.

### SPECIFICATIONS

**Temperature (Operating):** -40 to +85 degrees C

**Temperature (Storage):** -55 to +105 degrees C

**Altitude:** Not specified or characterized - similar equipment is at 15,000 ft.

**Humidity (Operating/Storage):** 5% to 95% non-condensing.

**Vibration:** Not specified or characterized

**Shock:** Not specified or characterized

**MTBF:** Can be calculated upon request

**PCI Express:** 4-lane, Gen. 2

**Voltages Required:** +12V, +3.3 V (+/- 5%)

**Power:** Negligible since this is a passive adapter

**Size:** 4.376 inches x 6.00 inches; .062 thick (+/- 10%)

**Weight:** 65 grams (139 grams with fan assembly)

**Amperage XMC:** 8 amps VPWR +12V or +5V, 4 amps +3.3V, 1 amp +12V, 1 amp -12V

### ORDERING INFORMATION

**9296:** Short Length, Compact XMC to PCI Express adapter - 8X - VITA 61

**8366:** Short Length, Compact XMC to PCI Express adapter - 4X

**8367:** Short Length, Compact XMC to PCI Express adapter - 1X

**8254:** Optional fan assembly; ball-bearing blower style (11 cfm) with mounting hardware

**8241:** Compact XMC-to-PCI Express (PCIe) Adapter - 8X (Front-Panel I/O Only)

