

VPX Carrier/Adapter

VPX to PCI Express Adapter

The Technobox 3U VPX to PCI Express (PCIe) adapter provides a convenient and cost-effective means for developing 3U VPX boards in a personal computer environment. It can also be used for production testing of 3U VPX boards.

The adapter is a half-length PCIe card with the VPX card under test mounted close to the PCIe edge fingers to minimize signal lengths. When seated in a PC motherboard, the VPX card primary side faces upward to allow convenient access to components. Either a non-enclosed PC motherboard can be used, or the motherboard can be housed in a Desktop style PC cabinet with the cover remove to permit the VPX card to protrude through the side of the cabinet.

Depending on the Technobox Part Number purchased, the adapter provides 1 lane (P/N 8464), 4 lanes (P/N 8462), or 8 lanes (P/N 8065) of PCIe connectivity between the VPX board and the PC motherboard. Users must consider the target PCIe slot into which the adapter will be plugged to purchase the correct adapter.

VPX differential wafers P1-9 thru P1-16, and P2-1 thru P2-16, are connected to 0.1-inch centered headers on the adapter for convenient access to VPX user I/O signals. VPX P1-1 thru P1-8 are reserved for PCIe

lane connectivity, with one lane per wafer for a total of up to 8 lanes. The P1 PCIe signals are connected per VITA 46.4 standard PCIe on the VPX Fabric Connector.

The P0 VPX utility connector, which provides VPX power, is pinned out per VITA 46.0 P0 Utility Connector for 3U applications (Vs1 = +12V, Vs2 = +3.3V, Vs3=+5V). Please beware that 3U power on P0 is incompatible with 6U power, so this adapter must only be used with 3U VPX boards. The adapter has a +12V to -12V POLA DC to DC converter on board which provides -12V to the -12V_AUX power rail on the VPX P0 connector. Since the PCIe edge finger does not provide +5V power, P0 "Vs3" +5V power can be supplied via a 4-pin Molex-style connector at the back edge of the adapter. This is connected to a +12V/+5V power connector normally used for powering HDD media in a PC. The Molex connector also provides additional power for the +12V rail. Vs2 3.3V power comes directly from the PCIe edge finger power rail.

The VPX standard specifies a 25 MHz reference clock (REF_CLK+/-) on P0; however, this adapter wires the 100MHz PCIe clock to these pins, a practice which is allowed by VITA 46.4. VPX cards relying on a 25 MHz clock frequency on REF_CLK will not work with this adapter. VITA 46.4 Rule 4-1 suggests PCIe-connected VPX cards should



8065

- Develop/production Test 3U VPX Cards in a PC
- Half-length (6.4") PCIe card
- Supports 1x, 4x, & 8x PCIe lanes
- User I/O on P1 & P2 Connectors Wired to 0.1-Inch Headers
- P0 Utility Connector Supports Vs1/Vs2/Vs3 of +12, +3.3, & +5V
- P0 -12V_AUX Supported Via on Board POLA DC to DC Converter
- +5V Power to VPX via 4-pin Molex-style Disk Power Supply Connector
- 100 MHz VPX Reference clock from PCIe REF_CLK
- DIP Switch for Setting VPX Geographical Address
- DIP Switch Setting NVMRO
- Adjustable VPX Guide Pin Orientation
- Convenient Hookup of VPX IPMI Signals
- JTAG Support Via PC Motherboard or USB-Blaster Cable
- Industrial Temperature Range

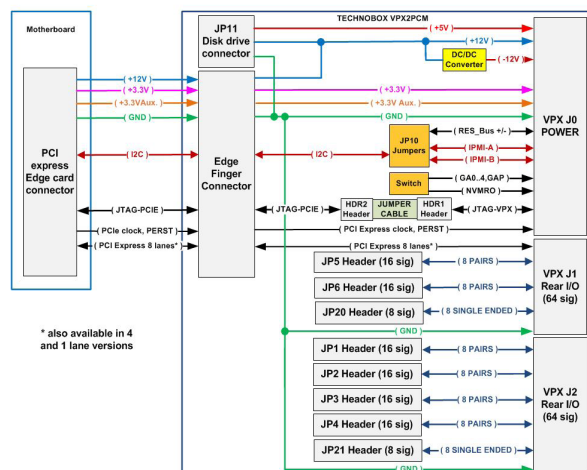

Technobox[®], inc.

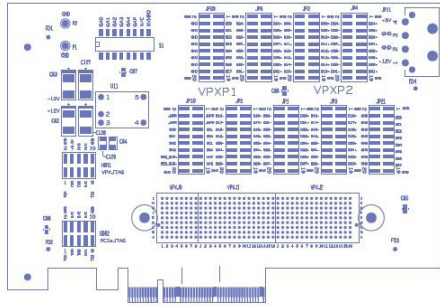

COMPONENT PLACEMENT VIEW - SIDE #1

not rely on REF_CLK at all, using instead a locally generated 100MHz clock for the PCIe interface. VPX cards might also be designed to operate with either 25 MHz or 100MHz REF_CLK.

An on-board DIP switch establishes VPX Geographical Address/Parity and also controls the non-volatile memory read-only (NVMRO) signal to the VPX board.

The adapter provides VPX guide pins. The key orientation can be easily changed by loosening the nut that secures the guide pin and then re-securing the guide pin with an orientation compatible with the VPX board under test.

On-board jumpers provide connection between either the VPX IPMA or VPX IPMB I2C busses and the single IPMI connection to the PC motherboard. Alternatively, users

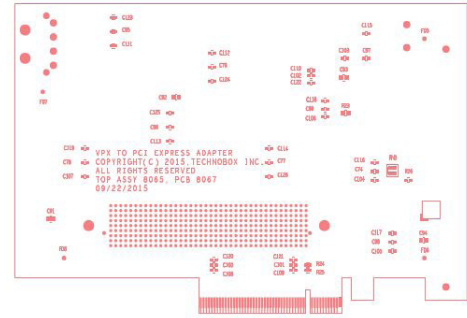

COMPONENT PLACEMENT VIEW - SIDE #2

can wire-in an external IPMI connection using these headers if the PC motherboard does not support IPMI.

JTAG continuity between the VPX board and the PC motherboard is provided via a supplied 10-pin ribbon cable. Users who wish to access the VPX board JTAG independently of the PC motherboard can remove this ribbon cable and connect a suitable JTAG cable, such as an Altera USB-Blaster cable.

SPECIFICATIONS

Temperature (Operating): -40 to +85 degrees C

Temperature (Storage): -55 to +105 degrees C

Altitude: Not Specified or Characterized. Typical similar equipment is at 15,000 ft.

Humidity (Operating/Storage): 5% to 90% non-condensing.

Vibration: Not specified or characterized

Shock: Not specified or characterized

MTBF: Available on request

Weight: 129 grams

Power: Minimal based on passive design

PCI Express: 8 lanes P/N 8065, 4 lanes P/N 8462, 1 lane P/N 8464

PCI Express Clock: 100MHz or as per the VPX in use

Voltages Required Adapter: +3.3V, +3.3V Aux, +12V
Tol: +/-5%

Voltages Supplied VPX: +12V, -12V, +5V, +3.3V
as per VPX in use

Size: 6.400" x 4.377" (PCB dimensions)

ORDERING INFORMATION

8065: Basic 3U VPX to 8 Lane PCI Express Adapter

8462: Basic 3U VPX to 4 Lane PCI Express Adapter

8464: Basic 3U VPX to 1 Lane PCI Express Adapter

6479: Extraction tool and wooden backing block (purchase separately; one per installation is recommended)

