

Asynchronous I/O PMC

8-Port RS232 Async Communication PMC

This eight-port async communication adapter provides eight industry standard 16550-based UARTs using RS232 signaling levels.

Each port provides the full set of data and modem control lines configured for DTE (i.e., computer side) operation:

- RTS (Request to Send)
- CTS (Clear to Send)
- TXD (Transmit Data)
- RXD (Receive Data)
- DCD (Data Carrier Detect)
- DTR (Data Terminal Ready)
- DSR (Data Set Ready)
- RI (Ring Indicator)

All eight ports are available out the PMC front panel on J1 68-pin SCSI-style connector.

FAST/WIDE SCSI cables can be used to connect between J1 and the users system wiring.

All eight ports are also wired to the PN4 connector at the rear of the PMC, allowing connection to the VMEbus P2 connector for host processors supporting rear-I/O. These signals are carried on the "a" and "c" rows

on the P2 connector. There are other standard connection configurations for the P0/J0 (enhanced VME and cPCI) and the "d" and "z" rows of an enhanced DIN connector.

Since the PN4 signals and J1 signals are in parallel and are not buffered, it is not possible to use both connections simultaneously.

The UARTs operate at standard baud rates from 300 baud to 115K-baud. Other odd-baud rates are possible and are available on special order. The UART IC used is a 16C554, which contains four independent 16550 UARTs.

The bridge between the 16550 register set and the PCI bus is a PLX 9030 chip this is a slave only device so all access from the host processor is done through programmed I/O to the PCI bus I/O space, as is customarily done for Async communication software. Once the registers are mapped into host I/O space, standard Async communication drivers may be used to access the ports.

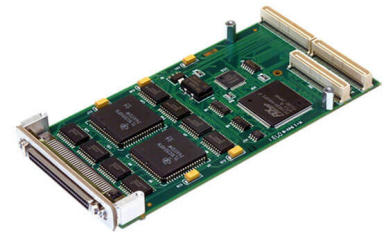

5284

- 8-port Async I/O RS-232
- Front & Rear Access
- True 16550 UARTS (TI 16C554), Up to 115K Baud Standard
- 32-bits / 33 MHz PCI bus (PLX 9030)
- 3.3V or 5V PCI Signaling
- Drop-in Replacement for Technobox P/N 2229 (Vendor & Device IDs Preserved, Register Compatible)
- RoHS-compatible
- Lead-free

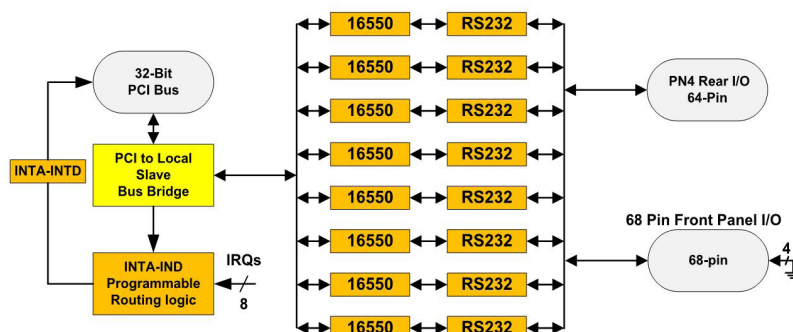

Technobox[®], inc.

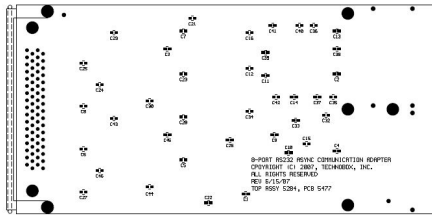

COMPONENT PLACEMENT VIEW - SIDE #1

The eight interrupt requests from each UART are routed to one of the four INTx lines on the PCI bus. This design avoids interrupt routing switches by incorporating a program-mable element which can be set up from the host processor, allowing any UART to be routed to any INTx request line. The default after reset is all UART interrupt requests are routed to the INTA line.

Transition panels from Technobox converts the 68-pin

SCSI style connector to eight 9 pin D-Sub connector or terminal blocks. For Rear I/O, a paddle card, Technobox P/N 1871, converts the P2 'a' and 'c' rows back into the 68-pin SCSI style connector. This permits use of the eight port 68 pin SCSI style transition panels.

Technobox P/N 5284 is a ROHS and Industrial temperature upgrade for the Technobox P/N 2229 and is a drop-in replacement. While the 2229 used a PLX 9052 bridge chip

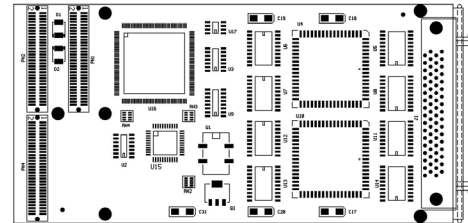

COMPONENT PLACEMENT VIEW - SIDE #2

and is useable on 5V PCI signaling carrier cards only, the 5284 uses a PLX 9030 bridge chip allowing use with 3V or 5V PCI signaling carrier cards.

Please contact Technobox for software support.

SPECIFICATIONS

Temperature (Operating): -40 to +85 degrees C

Temperature (Storage): -55 to +105 degrees C

Altitude: Not Specified or Characterized. Typical similar equipment is at 15,000 ft.

Humidity (Operating/Storage): 5% to 95% non-condensing.

Vibration: Not specified or characterized

Shock: Not specified or characterized

MTBF: Available on request

Typical Power Dissipation: TBD

Power Supplies Required: +5, +12, and -12 Volts

PCI Environment: 3.3V or 5V

ORDERING INFORMATION

5284: 8-Port RS232 Async Communication PMC

