

Asynchronous I/O PMC

4-Port RS232/RS422/RS485 Async Communications Adapter XMC

The Technobox 4-port Async Communications Adapter is a cost-effective solution for providing additional RS232/RS422/RS485 based async serial ports for a host processor.

Each port is independently set up by Technobox to operate at either RS232 or RS422 levels. In the RS422 case, an additional option is provided to transmit data on the receive data line in an RS485 fashion. Please specify your port configuration when ordering.

When configured for RS232 mode, a port provides the full set of data and modem control lines - RTS, CTS, TXD, RXD, DCD, DTR, DSR, and RI.

When configured for RS422 mode, a port provides TXD, RXD, CTS, and RTS, each operating at RS422 differential levels with unidirectional drive.

The RS485 mode supports both 2-wire and 4-wire RS485 connections. In 2-wire mode, a

single differential RS422 driven pair carries transmit or receive data in a half-duplex fashion. For 4-wire mode, the TXD is also driven on an additional RS422 unidirectional output. Control of transmit/receive direction is accomplished via the RTS control signal from the 16650 UART, as is customarily done for RS485 applications.

Options to terminate the differential RS422/RS485 signals with 150 ohm parallel termination are provided by the design. Please specify your termination requirements on order.

Three of the four ports are accessed via 9-pin "Micro" D Sub-miniature connectors on the PMC front-panel. All four ports are also available out the rear-I/O connector on the PMC, and are available out the P2 VMEbus connector for host processors which support rear-I/O connectivity. The P2 pinning is defined so that an IDC terminated Ribbon cable is



4960

- Provides 4 Async Serial Ports (16550 UARTS)
- Each Port Configurable as RS232, RS422 or RS485
- Micro D9 Sub-Miniature Front-Panel Connectors
- Selectable PCI Interrupt Configuration
- Optional Cable Assembly Supports Standard DB-9 Interface
- RoHS-compatible
- Lead-free

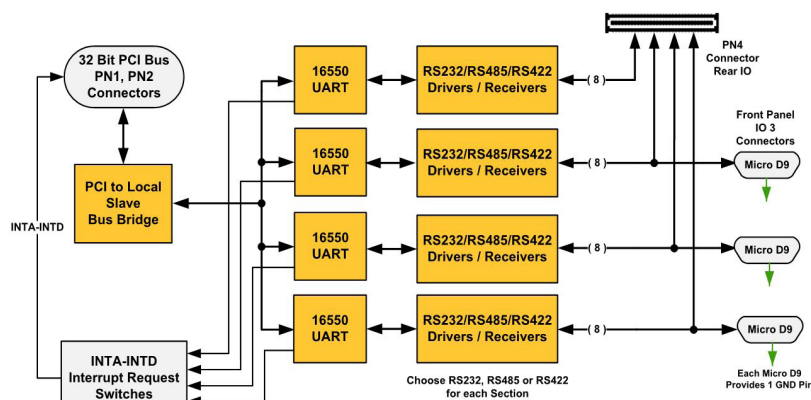

Technobox[®], inc.



COMPONENT PLACEMENT VIEW - SIDE #1

broken out to four individual 9-pin Standard D-Subminiature connectors for rear-I/O connection.

Switches on the board direct the interrupts from each port to the desired INTA/INTB/INTC/INTD request on the PCI bus. Any combination of connection to the INTx lines is possible,

thereby supporting shared and non-shared interrupt requests.

Industry standard 16550 UARTS operating up to 115K baud are used in this product. The 16550 register set is accessed from the host processor using Programmed-I/O. "C" source code is provided with the board to illustrate how to set up the

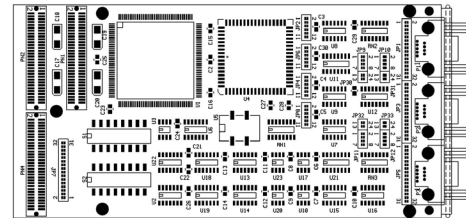

COMPONENT PLACEMENT VIEW - SIDE #2

PCI bus bridge in order to access the UART registers. Once the registers are mapped into host I/O space, standard async communication drivers may be used to access the ports.

SPECIFICATIONS

Temperature (Operating): -40 to +85 degrees C

Temperature (Storage): 55 to +100 degrees C

Altitude: Not Specified or Characterized. Typical similar equipment is at 15,000 ft.

Humidity (Operating/Storage): 5% to 95% non-condensing.

Vibration: Not specified or characterized

MTBF: Available on request

Typical Power Dissipation: TBD

Power Supplies Required: +5, +12, -12

PCI Environment: 5V, 32-bit / 33 MHz PCI

ORDERING INFORMATION

4960: 4-port RS232/RS422/RS485 Async Communications Adapter PMC

2402: Cable Assembly

