

XMC Carrier/Adapter

PCI Express to XMC Adapter

This passive 8 lane XMC-to-PCI express carrier card permits the use of PCI express 1 lane, 2 lane, 4 lane, 8 lane or 16 lane cards on XMC carrier boards.

The female PCI express connector on the secondary side operates at widths of 1 lane through 16 lanes, although only 8 lanes are connected, as a result for a 16 lane board, lanes 8 thru 15 will not be connected.

On the XMC primary side of the P15 connector all 8 PCI express lanes connect up with the female PCI express connector. The reserved future use, RFU, signals from P15 are available on one of the user connectors.

On the XMC primary side all the P16 connector signals have been brought out to connectors UC1 and UC2.

The P16 differential pairs have been laid out so that the differential pairs line up with twisted pair

ribbon cables. The P16 single-ended signals have also been brought out to UC1 and UC2.

A 32 pin header is available parallel to UC1 and UC2 for grounding purposes.

Several activity LEDs located at the edge of the board give an indication of key XMC and PCI Express signals and voltages.

The JTAG signals from the XMC bus and the PCI express bus are brought out to headers allowing users the option of connecting the PCI express JTAG port to the PMC JTAG port or connecting JTAG devices to either port. The I2C signals for both buses are brought to the same headers.

A PMC/XMC type front-panel provides firm positioning of the board where an XMC/PMC mounting panel is available.



4876

- Adapts a PCIe Card to an XMC Site
- Supports up to 8 PCIe Lanes
- Permits Access to P16 Signals, 12C & JTAG
- LEDs Show Key XMC Signals & Voltages
- Accommodates External Power
- RoHS-compatible
- Lead-free

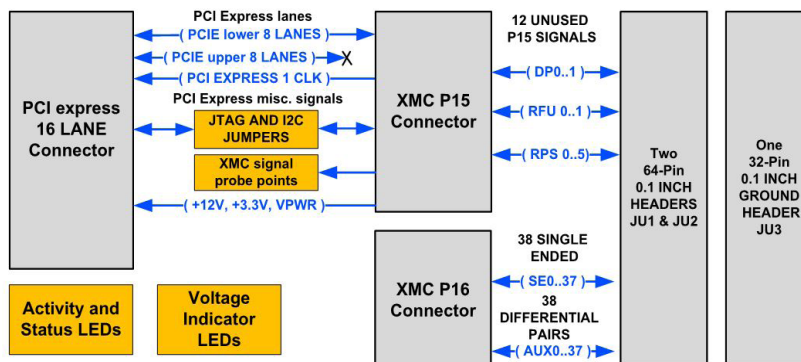

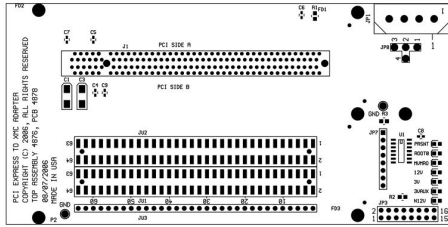

COMPONENT PLACEMENT VIEW - SIDE #1

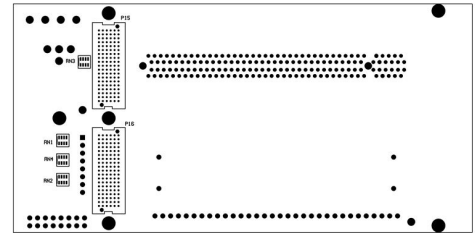

COMPONENT PLACEMENT VIEW - SIDE #2

SPECIFICATIONS

Temperature (Operating): -40 to +85 degrees C

Temperature (Storage): -50 to +100 degrees C

Altitude: Not Specified or Characterized. Typical similar equipment is at 15,000 ft.

Humidity (Operating/Storage): 5% to 95% non-condensing.

Vibration: Not specified or characterized

MTBF: Available on request

Typical Power Dissipation: Per PCI Edge Card under test

PCI Environment: 8 Lane Passive Adapter, +3.3V, +12V, +5V

ORDERING INFORMATION

4876: PCI Express to XMC Adapter Carrier

