

# Asynchronous I/O PMC

## 2-Port RS232/422/485 Async Communication Adapter

The Technobox 4-port Async Communications Adapter XMC is a cost-effective. The 2-port Async Communications Adapter is a cost-effective solution for providing additional RS232/RS422/RS485 based serial ports for a host processor.

Using configuration switches on the PMC board, each port is independently set-up at either RS232 or RS422 levels. In the RS422 case, an additional option is provided to transmit data on the receive data line in an RS485 fashion.

When configured for RS232 mode, a port provides the full set of data and modem control lines - RTS, CTS, TXD, RXD, DCD, DTR, DSR, and RI.

When configured for RS422 mode, a port provides TXD, RXD, CTS, and RTS, each operating at RS422 differential levels with unidirectional drive.

The RS485 mode supports both 2-wire and 4-wire RS485

connections. In 2-wire mode, a single differential RS422 driven pair carries transmit or receive data in a half-duplex fashion. For 4-wire mode, the TXD is also driven on an additional RS422 unidirectional output. Control of transmit/receive direction is accomplished via the RTS control signal from the 16750 UART, as is customarily done for RS485 applications.

Options to terminate the differential RS422/RS485 signals with 150 ohm parallel termination are provided by the design.

The two ports are available out the PMC front-panel using standard 9-pin male D-Subminiature connectors. For RS232 mode, the pin-out is the same as the Personal Computer 9-pin COM port. Use of standard DB9 connectors avoids the need for special external adapter cables, so any readily available 9-pin COM cable can be used.

Switches on the board direct the interrupts from each port to

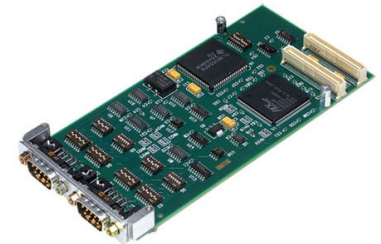

# 2901

- Uses Leaded Solder

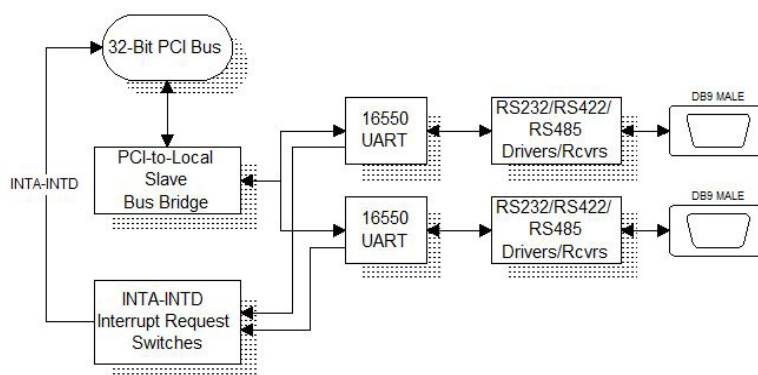

**Technobox<sup>®</sup>, inc.**

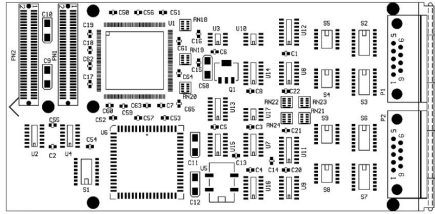

**COMPONENT PLACEMENT VIEW - SIDE #1**

the desired INTA/INTB/INTC/INTD request on the PCI bus. Any combination of connection to the INTx lines is possible, thereby supporting shared and non-shared interrupt requests.

Industry standard 16550 UARTS operating up to 115K-baud

are used in this product. The 16550 register set is accessed from the host processor using Programmed-I/O.

“C” source code is provided with the board to illustrate how to set up the PCI bus bridge in order to access the UART registers.

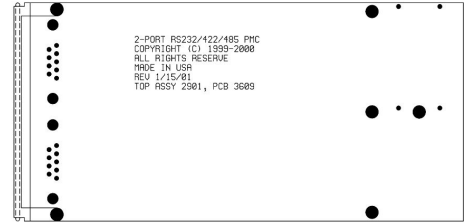

**COMPONENT PLACEMENT VIEW - SIDE #2**

Once the registers are mapped into host I/O space, standard async communication drivers may be used to access the ports.

### **SPECIFICATIONS**

**Typical Power Dissipation:** TBD Watts

**Power Supplies Required:** +5, +12, -12

**PCI Environment:** 5 Volt

### **ORDERING INFORMATION**

**2901:** 2-Port RS232/422/485 Async Communication Adapter

