

# PMC-X Dual/Quad 82551ER 10/100-TX Ethernet Adapter

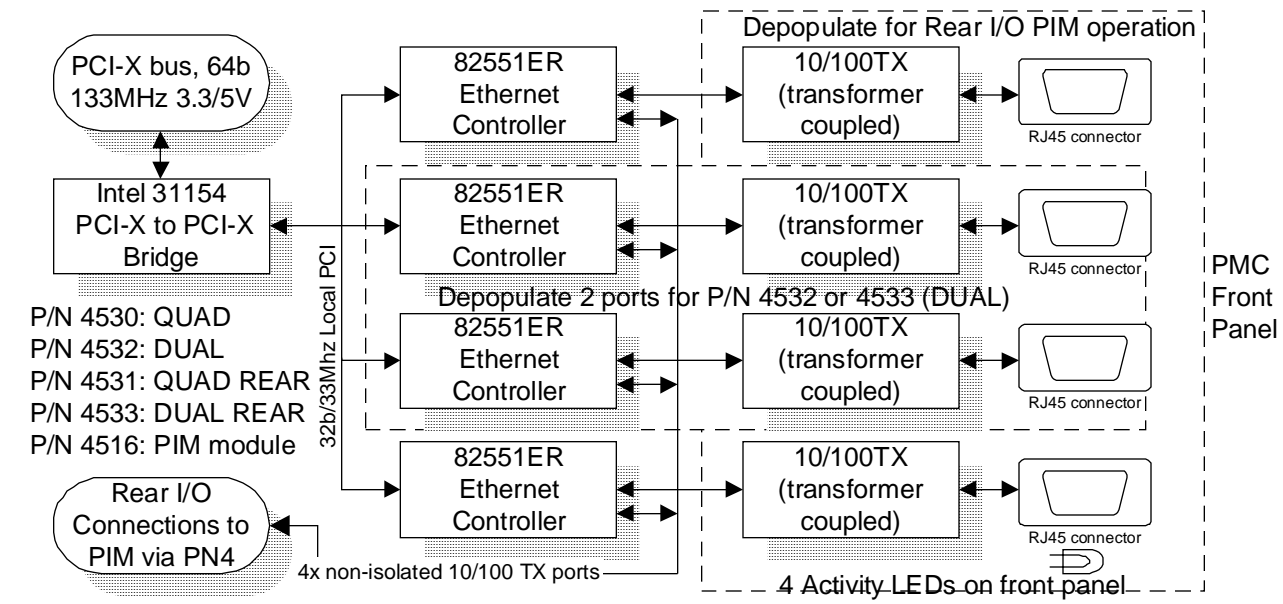

The Dual/Quad 10/100-TX Mb/s Ethernet PMC-X (per VITA 39) Adapter provides up to four Ethernet connections over twisted pair media. Options are available for Front-Panel RJ45 accessibility, or Rear I/O accessibility via a VITA 36 PIM module.

The card is built around Intel 82551ER Ethernet controllers that provide an integrated media access controller (MAC) and physical layer (PHY) for operating at either 10 Mb/s or 100 Mb/s. The 82551ER provides full-duplex operation at both speeds.

For front panel I/O the module presents four RJ-45 connectors, one for each port, eliminating the need for cumbersome cable adapters. Transformer based electrical isolation is provided between the 82551ER and the I/O connectors.

For the front-panel accessible products, one Green/Yellow status LED is available for each port and is visible on the front panel. The LED will illuminate GREEN for 100 Mb/s operation, and YELLOW for 10 Mb/s operation, and will illuminate upon sensing a valid link condition. During operation, the LEDs will flicker OFF to indicate packet activity on the corresponding Ethernet port.

The connection to the PCI-X bus is through an Intel 31154 bridge. When host software properly configures the bridge, each 82551ER controller appears as if it were an independent controller on the primary side of the bridge. With this bridge, operation on the primary PCI bus is possible at normal PCI speeds and protocol (32/64b, 33/66MHz, 3.3/5v signaling) as well as PCI-X

speeds and protocol (64b, 66/100/133MHz, 3.3v signaling) as automatically selected by the M66EN and PCI-XCAP signals. The local PCI bus that handles the 82551ER controllers operates at 32b/33MHz, and the 31154 bridge hands translation between clock and width domains.

Interrupt requests A, B, C, and D are posted on the PCI bus, using the standard PCI-to-PCI bridging conventions for routing interrupts from devices on the secondary side of a bridge.

Each port is programmed with a unique 48-bit MAC address that is stored in EEPROMs on the board.

The fully populated board (P/N 4530) has all four Ethernet ports available at the PMC front panel. A depopulated version of the board (P/N 4532) is available that provides two ethernet ports using a front panel machined with two RJ45 openings.

Other population options are available for supporting Ethernet access via the PMC's PN4 connector for Rear I/O access. P/N 4531 supports four Ethernet ports, while P/N 4533 supports two Ethernet ports. A P/N 4516 VITA 36 "PIM" module is required to support transformer isolation to the Ethernet cables. These rear I/O PMCs have a blank front panel. The PIM has the RJ45 connections as well as the four green/yellow status LEDs.

The Intel 82551ER is supported by many operating systems with built-in Ethernet support.

# PMC-X Dual/Quad 82551ER 10/100-TX Ethernet Adapter

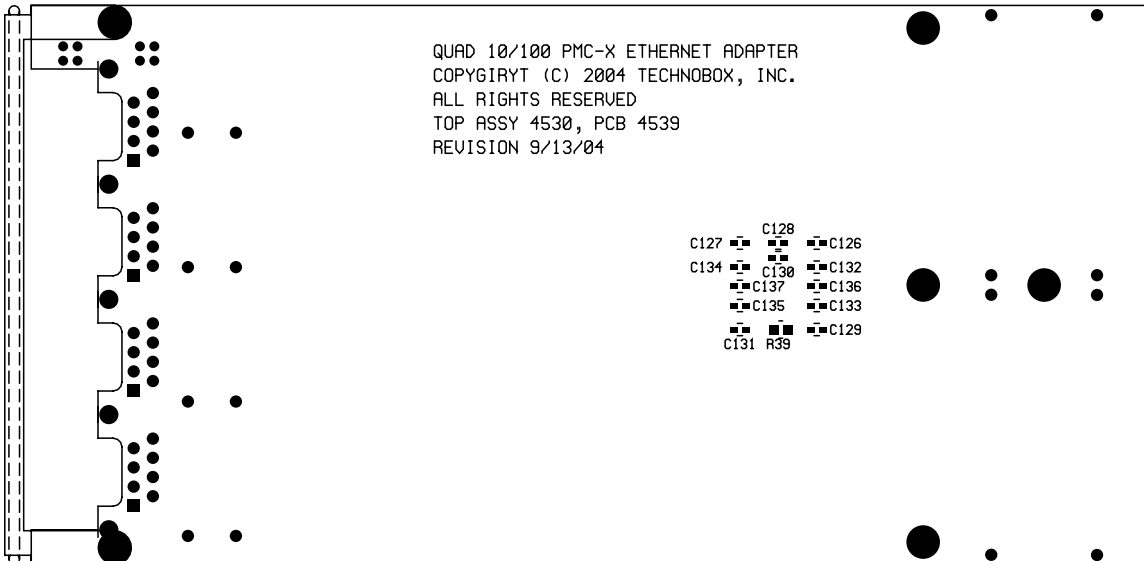
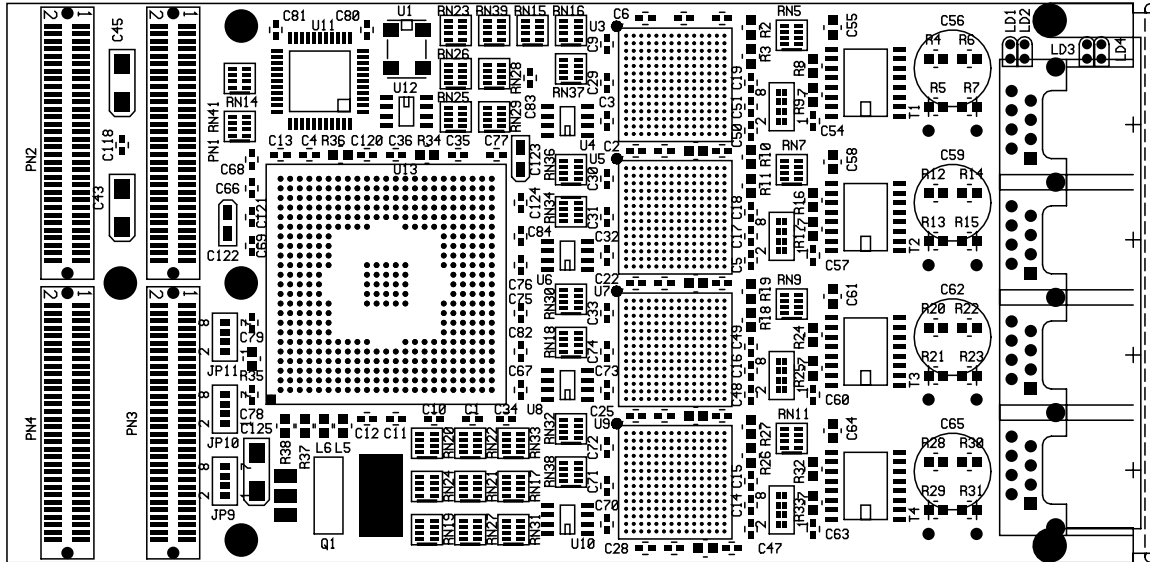

## Product Summary

Technobox Part Number:	4530 : Quad Ethernet Population F/P I/O 4532 : Dual Ethernet Population F/P I/O 4531 : Quad Ethernet Rear I/O (use 4516 PIM) 4533 : Dual Ethernet Rear I/O (use 4516 PIM) 4516 : Quad Ethernet PIM (use also for Dual application)
Typical Power Dissipation:	TBD watts
Power Supplies Required:	+3.3 volt
PCI Signaling Environment:	5 Volt or 3.3 Volt, 32/64-bit, 33/66 MHz (PCI) or 66/100/133 MHz (PCI-X)