

32-Channel, 16-bit A:D Converter

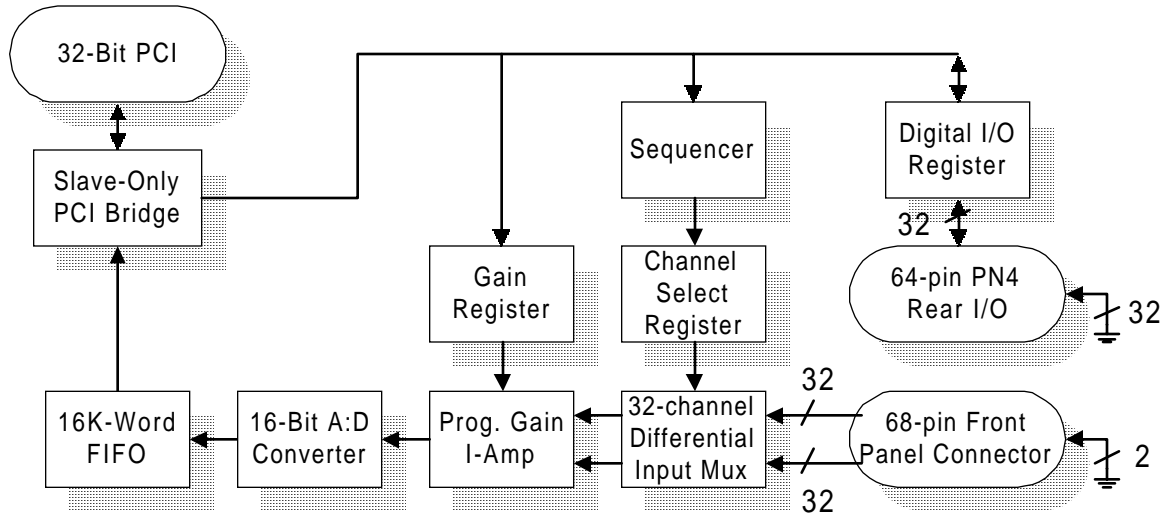

The 32-channel, 16-bit A:D converter card from Technobox provides a combination of digital and analog interfaces on a single-wide PMC.

Thirty-two digital I/O lines, each with a corresponding ground, are available at the 64 user I/O pins on PN4 of the PMC. For VMEbus hosts supporting rear I/O connectivity, these signals are connected to the standard P2 connector user I/Os.

The digital I/O is organized in four blocks of eight channels per block. Each block is programmed from the host for digital input, or digital output. On reset, the digital I/O defaults to input mode.

32-channels of differential analog input are provided via a 68-pin connector at the front panel. This connector is compatible with SCSI-III standard, permitting cost effective, readily available differential cables for use in the application. Also, Technobox provides an optional transition panel, which breaks out the 32-channels into individual screw-terminals.

The design uses a differential analog multiplexer feeding a programmable gain instrumentation amplifier followed by a 192 Ks/s 16-bit Delta-Sigma Analog-to-Digital converter.

The A:D converter uses 64 times oversampling, with comb and finite impulse response (FIR) filters. For single channel sampling operation, this on-board filtering eliminates complex anti-aliasing circuitry for periodic sampling applications. *When operating in multi-channel multiplexed mode, anti-aliasing is not supported.*

The overall gain of the analog circuit is controlled by gain and attenuation networks, allowing virtually any analog input range to be accommodated by this board. A 2-bit gain register provides 1x, 2x, 4x, and 8x programmable gains for the instrumentation amplifier. Gain and offset trimming potentiometers optimize performance of the analog section. Please contact Technobox to discuss your specific analog input requirements.

One of thirty-two analog inputs is selected by a 32-channel, differential input, analog multiplexer, controlled by a digital sequencer. The sequencer is programmed by the host processor for single-channel continuous sampling analog input of a selected channel, or rotational sampling of all 32-channels. The sampling rate is adjustable under program control from the host processor, up to 192 Ks/s aggregate across all channels.

The 16-bit digitized analog data is presented to a 16-Kword deep FIFO, which is accessible from the PCI interface. The FIFO output ready, and half-full outputs are visible to the host program, and may be configured by the host program to present an interrupt request to the PCI bus.

The PCI interface is a slave-only design. The FIFO is mapped into the host processor memory space, allowing efficient block-transfer movement of data from the FIFO to buffers located in host processor memory.

32-Channel, 16-bit A:D Converter

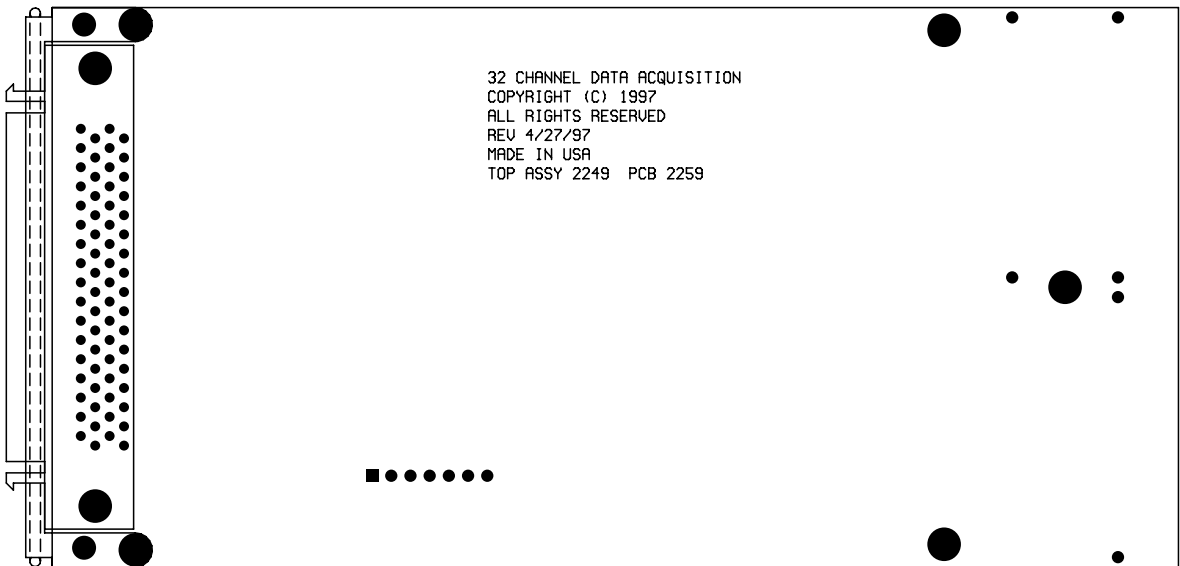
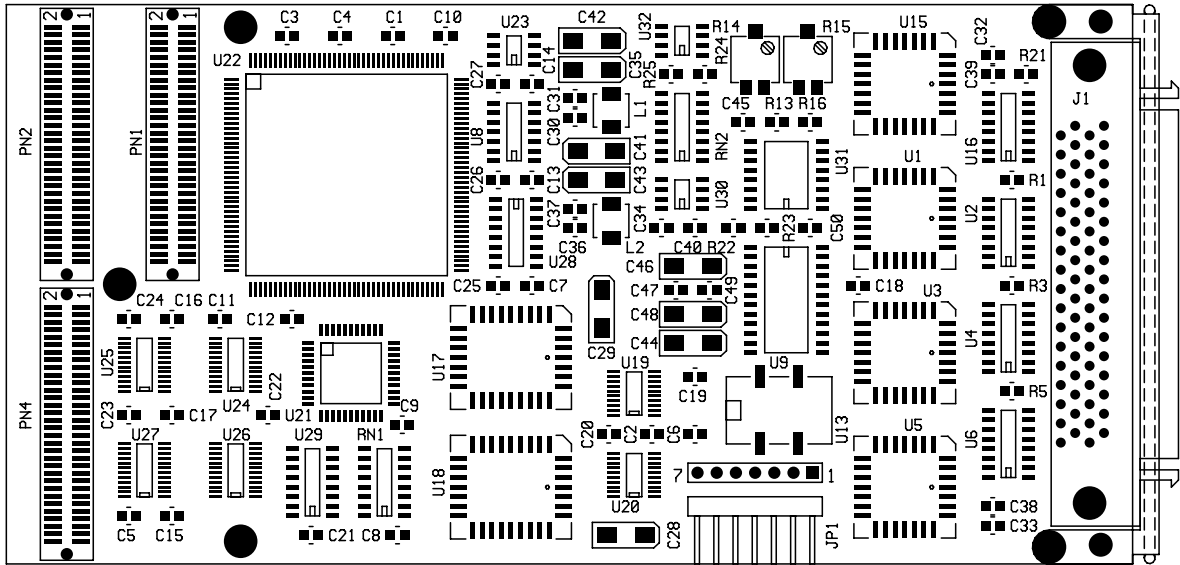

Product Summary

Technobox Part Number:	2249
Typical Power Dissipation:	TBD watts
Power Supplies Required:	+5, +12, -12
PCI Signaling Environment:	5 Volt