

Asynchronous I/O XMC

8-16 Port Configurable Async Product Family

The Technobox, Inc Conduction-Cooled RS232/422/485/GPIO Asynchronous Communication Adapter product family features the XR17V358 controller and can support up to 16 UART based ports at RS232, RS422, and RS485 electrical levels. Ports may be manufactured to support Digital I/O.

As a result of the adapter's architecture, millions of unique combinations of I/O signaling levels can be quickly realized. By selecting the appropriate port configuration and termination, the specific custom configuration can be created to meet your requirements.

Once a custom configuration is specified, a Technobox, Inc. orderable part number will be assigned to identify the configuration and make

the product easy to re-order.

For example, all ports may be 8 signal RS232 COM ports, using one XR17V358 chip. All ports may be 4 signal RS232 COM ports (RXD,RXD, CTS,RTS), with two UART chips populated. Furthermore, customer-specific applications requiring mix of various interfaces - RS232,RS422, RS485 and GPIO - is easily achieved.

The design is exceptionally versatile and is partitioned into eight "sections," each manufactured to support any of the following:

- RS232: Standard 8 COM port signals
- RS422: Standard 4 COM port signals (RXD,TXD,RTS,CTS)
- "Split partitioning" of the section into two independent functions.

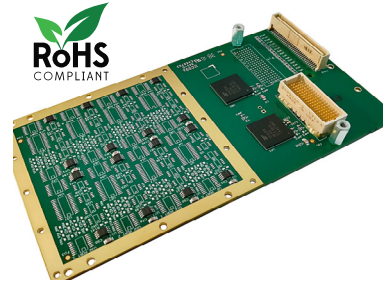

Rear I/O

- EXAR XR17V358 Octal UARTs
- Up to 16 Asynchronous ports using two UART chips
- Each port can be uniquely configured
- Standard Baud rates up to 115KBaud & Baud rates up to 31.25MBaud
- Migration path from existing PMCs to XMC
- Supports general purpose DIO
- Implemented w/o jumpers /mezzanines/FPGAs
- 1x Gen 1 (2.5 Gb/s) PCIe connection
- PN4 & J16 rear I/O connectors
- PN4 configurable for VITA 46 or standard pairing
- Conduction-cooled rear I/O XMC
- Powered Only by XMC 3.3V Rail
- Industrial Temperature Design
- RoHS Compliant
- Carrier Cards Available

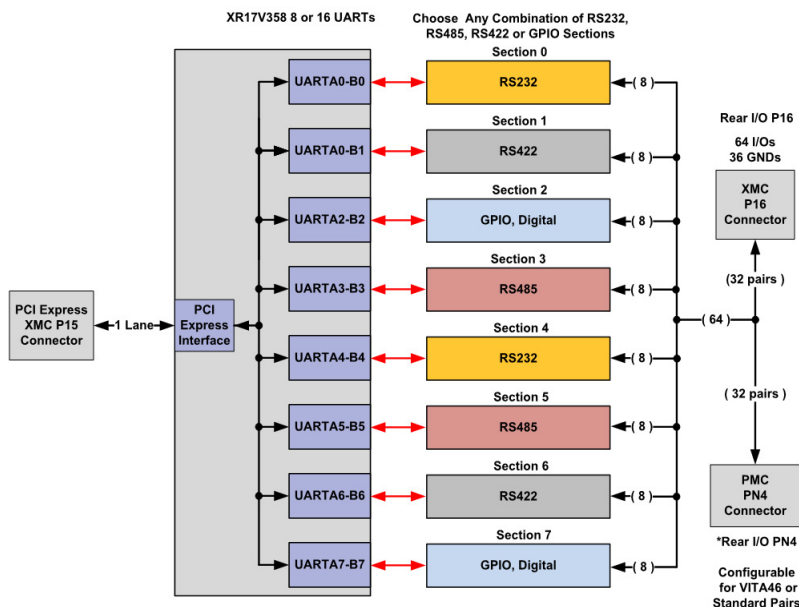

When a section is configured for "Split partitioning," each half of the section is manufactured to support any of the following:

- RS232: Standard 4 COM port signals (RXD, TXD, RTS, CTS)
- RS422: Standard 2 COM port signals (RXD, TXD)
- RS485: Bidirectional RS485 data on one differential pair (TX, RXD)
- GPIO: Two bits of General Purpose, series terminated Digital IO.

Note that when at least one section is split, a second XR17V358 UART is populated on the board.

To facilitate quick turn delivery to customers, a ready inventory of partially assembled boards is kept in

stock. The secondary side is populated the same way for all configurations, consisting of mostly bypass capacitors and common elements.

When a customer order is received, the primary side is then populated appropriately, resulting in the customer required configuration. Changes in termination resistances, XMC connector (VITA 42 or VITA 61), which are variations on the primary side population, are easily and quickly accomplished.

Employing this unique method of selective population results in highly reliable, highly configurable Async boards without using any jumpers, plug-on mezzanines, or complex FPGAs.

The XR17V358 has exceptional features providing advanced high-performance Asynchronous communications. The standard 16550 UART is implemented. But additional operational modes allow deep FIFOs (256 bytes), automatic flow control (CTS/RTS or XON/XOFF), RS485 direction control, and baud rates to 31.25 Mbaud based on an internally generated 125 MHz clock, or 15.625 Mbaud for the second XR17V385 chip (see datasheet).

This single design covers the functionality of various existing Technobox, Inc. Async PMCs and permits a migration to XMC/PCIe:

Standard Configurations

Function	Stocked Configurations	XMC P/N	Notes
16-Port RS422	Rear I/O PN4	9119	RCV Term; TXD/RXD P15 (V61); PN4 (V46 Diff.)
15-Port RS422	Rear I/O PN4	9280	15 RS422 RCV Term; 1 RS485 2/ Term. P15 (V61); PN4 (V46 Diff.)
4-Port RS422	Rear I/O PN4	9290	4 RS422 RCV Term.; 8 RS 232; all RXD/TXD/CTS/RTS P15 (V42); PN4 (V46 Diff.)
8-Port RS422	Rear I/O PN4	9417	8 RS422 RCV Term. only; P15/16 V42); no PN4

This product family contains both air-cooled front-panel I/O and conduction-cooled rear I/O XMC. For rear I/O the part signals are routed to P16 and (possibly) PN4, and PN4 can be configured for VITA46 or standard pairing.

Various carrier cards are available for system development, deploy-

ment and test of the PN4 and P16 connectors in user friendly form factors. For example, P/N 4821 break out the P16 connector to pin headers. P/N 5933 connects the PN4 connector to a VME J2 style connector. P/N 8260 connects the PN4 and the J16 connector to a 68-pin front-panel connector for easy access and cable prototyping. Many

other carrier and adapter accessories are available.

This product is built with industrial temperature range parts (-40 to +85 C) and is RoHS compliant.

SPECIFICATIONS

Temperature (Operating): -40 to +85 degrees C

Temperature (Storage): -40 to +105 degrees C

Altitude: Not specified or characterized - similar at 15,000 ft.

Humidity (Operating/Storage): 5% to 95% non-condensing.

Vibration: Not specified or characterized

Shock: Not specified or characterized

MTBF: Can be calculated upon request

Weight: 45 grams TBD

Power: TBD dependent on configuration type

PCI Express: 1 lane, 2.5GHz Gen 1

Voltages Required: +3.3V only

Dimensions: 74mm x 143.7mm

PCB Thickness: 1.57mm / 0.062" +/-10% as per standard PCBs

ORDERING INFORMATION

9119: 16-Port RS422 - 121 ohms parallel termination on receive side only; TXD, RXD (V61, P15) w/PN4, no P16

9280: 15 RS433 RCV Term; 1 RS485 2/ Term. P15 (V61); PN4 (V46 Diff.)

9290: 4 RS422 RCV Term.; 8 RS 232; all RXD/TXD/CTS/RTS P15 (V42); PN4 (V46 Diff.)

9417: 8 RS422 RCV Term. only; P15/16 V42); no PN4

