

Network Adapter XMC

Quad 10/100/1000 Ethernet Convection-Cooled XMC

The Technobox, Inc. P/N 9096 Quad 10/100/1000 XMC provides four Intel i210 (WGI210ITSLJXT) Ethernet ports operating with BASE-T transformer-coupled interfaces.

Each i210 controller is connected to a PCI Express switch providing 4 lanes of GEN 2 capable connections to the host. Each controller is serviced by a 1-lane GEN 1 PCIe connection, providing ample bandwidth for operation at 1-Gb/s Ethernet speeds.

Each i210 controller is programmed with a unique 48-bit MAC address.

Two standard build variations are available. The air-cooled XMC (P/N 9096) has four RJ45 ports available at the front panel. The VITA 20 conduction-cooled version (P/N 9100) has four ports of transformer-coupled rear I/O available at P16, and no front panel. Additional variants, including those populated with VITA 61 and VITA 88 connectors, can be built. Contact Technobox for part numbers.

For the air-cooled 9096, four LEDs – one for each port - are available at the front panel. These show port link status and communication activity. LEDs are populated on the body of the board for the conduction-cooled P/N 9100.

A key feature of both designs is magnetic coupling. For P/N 9096, there is 1500V of isolation barrier and also common mode rejection for the front panel RJ45s. Note that for P/N 9100, however, isolation depends heavily on the clearance geometry of the carrier card signal path.

Standard operating systems, such as Linux and Windows, are supported.

These products are built exclusively with industrial temperature range components and are RoHS compliant. Only +3.3V power is required from the XMC P15 connector.

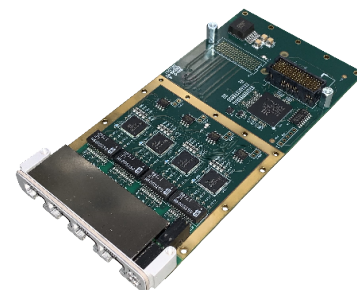

9096

- **Four Intel WGI210IT 10/100/1000 Ethernet Controllers**
- **4 Lane Gen 1 (2.5 Gb/s) PCIe Connection to the PCI Express Switch**
- **1 Lane Gen 1 (2.5 Gb/s) PCIe Connection to Each Ethernet Controller**
- **RJ45 front-panel Connectors**
- **Front-Panel Status & Activity LEDs on Air-Cooled Versions**
- **Powered Only by XMC 3.3V Rail**
- **Industrial Temperature Design**
- **RoHS Compliant**

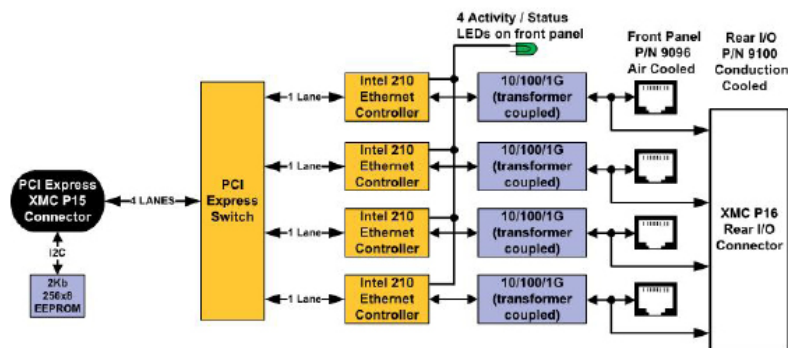

Technobox[®], inc.

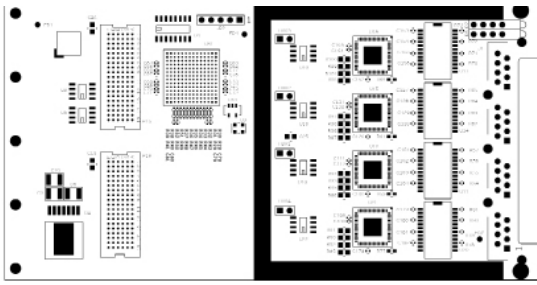

COMPONENT PLACEMENT VIEW - SIDE #1

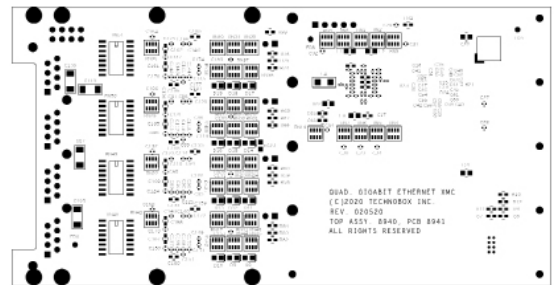

COMPONENT PLACEMENT VIEW - SIDE #2

SPECIFICATIONS

Temperature (Operating): -40 to +85 degrees C

Temperature (Storage): -55 to +105 degrees C

Altitude: Not specified or characterized. Typical similar equipment is at 15,000 ft.

Humidity (Operating/Storage): 5% to 90% non-condensing.

Vibration: Not specified or characterized

Shock: Not specified or characterized

MTBF: Available upon request

PCI Express: GEN-1 (2.5 Gb/s)

Voltages Required: +3.3V only

Power: TBD, prior generation power was 0.293 amp measured @ 3.3V

Size: 74 mm x 128.7 mm

PCB Thickness: 1.57mm / 0.062" +/-10% as per standard PCBs

Weight: 53 grams

ORDERING INFORMATION

9096: Quad 10/100/1000 Ethernet Convection-Cooled XMC

9100: Quad 10/100/1000 Ethernet Conduction-Cooled XMC

9911: Conformal-Coated Air-Cooled Quad Gigabit Ethernet

9928: Conformal-Coated Conduction-Cooled Quad Gigabit Ethernet

