

Storage Controller PMC

IDE Controller PMC with Front-Panel CF

The Front-Panel CompactFlash Adapter PMC, when mated to a host or carrier card, provides an interface between the PCI bus and two Type-I or Type-II CompactFlash (CF) devices mounted on the Adapter. One CF device, connected to the Primary IDE channel, is available out the front-panel.

A second CF device, connected to the Secondary IDE channel, is mounted on the body of the adapter and is secured with a locking mechanism. Additionally, the Secondary IDE channel of the adapter can interface other IDE/ATA devices, via its rear I/O connector (PN4).

Built around a Silicon Image PCI-680 IDE controller chipset, the product supports the Ultra 133 data-transfer protocol over the IDE channels. It also supports slower bus-master data transfer rates to accommodate hard disk drives (HDDs) and

CF devices that do not support Ultra 133.

The signals for DMA transfer support on Compact Flash are connected to the 680 controller.

The PCI bus is a 32-bit bus at 33 MHz. A built-in phase-lock loop generates an internal clock from the 33 MHz PCI bus clock. This internal clock is used to transfer data at the rate of 133 MB/sec on the IDE interface.

The CompactFlash sites are configured to operate in true IDE mode. PCMCIA mode is not required or supported. Additionally, the sites can be set to operate as either master or a slave device via DIP switches on the board.

On-board BIOS, provided by Silicon Image and resident in flash memory, supports boot up configuration. This feature is supported only on Intel platforms.

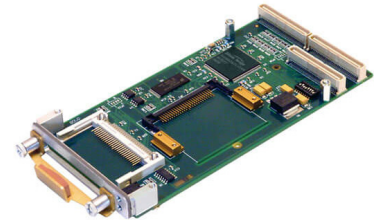

5264

- Supports 2 CF Devices (Type I or II)
- Silicon Image PCI680 Controller
- Ultra133 on Primary & Secondary Channels
- Front-panel CF Device on Primary Channel; On-board CF Site on Secondary; both w/ Positive Retention
- Supports DMA Transfer to CF Devices
- On-board BIOS Storage for Boot Configuration
- Front-panel Indicators Provide General Status & Activity
- RoHS-compatible
- Lead-free

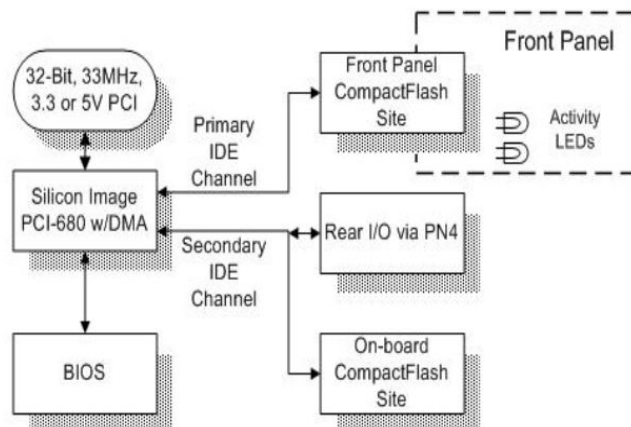

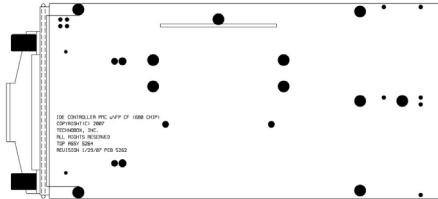

COMPONENT PLACEMENT VIEW - SIDE #1

Two LEDs on the front-panel provides activity status for the primary and secondary IDE channels.

The IDE Controller PMC supports four interrupts. Interrupt configuration is determined by DIP switch settings. Default setting is Interrupt A.

The product is the follow on to a prior generation 648-based adapter. This product is enhanced with a 680 chipset as well as support for an on-board

Compact Flash device and is RoHS compliant.

In addition, a screw-on locking mechanism is provided on the front-panel to secure the front-panel compact flash device to the adapter. The pin-out on PN4 for rear-I/O support is the same as on the 648-based adapter, however the Secondary IDE channel is connected to the PN4 instead of the Primary channel.

Please note that this product does not support "live-insertion"

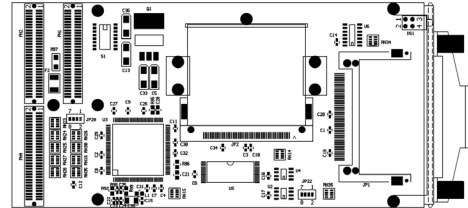

COMPONENT PLACEMENT VIEW - SIDE #2

of Compact Flash devices and should be viewed as a semi-permanent installation for CF devices. The system must be powered down prior to swapping out the front-panel CF device.

Please see Silicon Image (www.siim-age.com) regarding driver support for common operating systems.

SPECIFICATIONS

Temperature (Operating): -40 to +85 degrees C

Temperature (Storage): -55 to +105 degrees C

Altitude: Not Specified or Characterized. Typical similar equipment is at 15,000 ft.

Humidity (Operating/Storage): 5% to 95% non-condensing.

Vibration: Not specified or characterized

Shock: Not specified or characterized

MTBF: Available on request

Typical Power Dissipation: TBD

Power Supplies Required: 5 Volts

PCI Environment: 3.3V or 5V

ORDERING INFORMATION

5264: IDE Controller PMC with Front-Panel CF

5756: IDE Controller PMC with Front-Panel CF (Conformally-Coated)

6677: IDE Controller PMC with Front-Panel CF (w/ P/N 6735 installed)

6735: CF Guidance Plate Retrofit Kit

