

# Digital I/O PMC

## 2-Port RS232/RS422/RS485 Asyn Serial Communications Adapter PMC

The Technobox, Inc. P/N 4966 is a Two-Port Two-Port RS232/RS422/RS485 Asynchronous Communication Adapter PMCs which provide two 16550 UART based serial ports with user-configurable options for operation at RS232 single-ended, RS422 uni-directional differential, and RS485 bi-directional differential signaling levels in any combination for the four ports. The default configuration is RS232 levels.

Asynchronous communication rates up to 115 Kbaud are supported using the standard baud-rate crystal installed on the board. Higher baud rates (up to 1 Mbaud) are possible by changing the frequency of this crystal, which may find application in RS422 and RS485 environment. Please contact Technobox if you

have non-standard baud rate requirements for your application.

This product is ideally suited as a supplement to the Asynchronous Communication ports generally available on the VMEbus or equivalent host processor board. Additionally, operation with RS422 and RS485 levels are possible, which are generally not supplied on VMEbus host processor boards.

The two ports, consisting of 9 signal lines per port (i.e., 8 signals and 1 GND) are available out the front panel, and are individually accessed via standard DB9 male connectors.

The signal pinout for the DB9 connector follows the same scheme as used on Personal

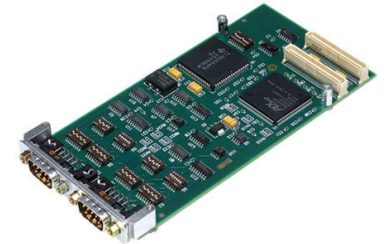

### 4966

- Dual-Port Async Serial I/O
- DB-9 Front-Panel Interface
- 32-Bit PCI Bridge (PLX 9030)
- Programmed I/O
- User Configurable for RS-232 (Standard), RS-422 & RS-485
- Two 16550 UARTs Using TI TL16C554
- Rates up 115 Kbaud Standard (Up to 1 Mbaud by Crystal Change)
- Interrupt Configuration via DIP Settings

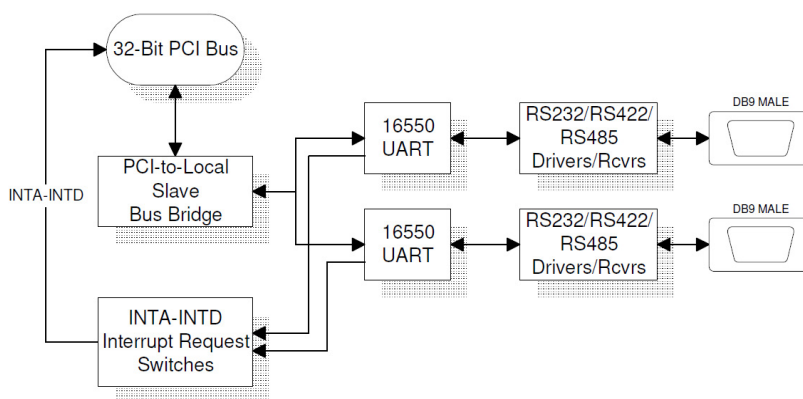

**Technobox<sup>®</sup>, inc.**

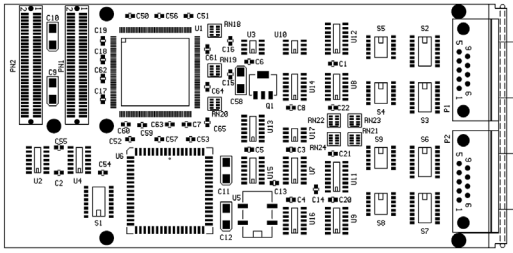

**COMPONENT PLACEMENT VIEW - SIDE #1**

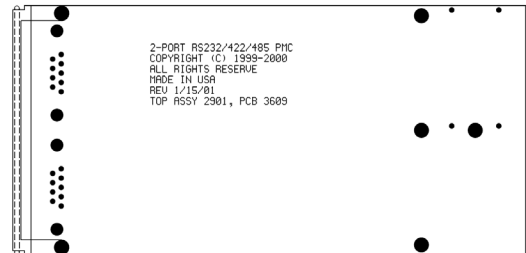

**COMPONENT PLACEMENT VIEW - SIDE #2**

Computer 9-pin serial ports, and are therefore wired for “DTE” mode operation, intended to be connected to “DCE” (peripheral) equipment. To connect the board to another DTE device (such as another P/N 2901 board), a null modem is required.

The UART used in this design is an industry standard 16550 architecture. The actu-

al chip used in the design is a 16C554, which contains four independent 16550 UARTs.

The bridge between the 16550 UARTS and the PCI bus is a PLX 9030 chip, produced by PLX Technology, Inc. This is a slave-only chip, so all access to the 16550 UARTs is done through Programmed I/O to the PCI bus I/O space, as is customarily done with Async

Communication software. Each UART provides an interrupt to the PCI bus. Unique to the Technobox design is the ability to configure, via DIP switches on the PMC board, routing the UART interrupts to any combination of the wire-or’d INTA, INTB, INTC, and INTD interrupt request lines on the PCI bus.

### SPECIFICATIONS

**Temperature (Operating):** -40 to +85 degrees C industrial-grade

**Temperature (Storage):** -40 to +100 degrees C

**Altitude:** Not Specified or Characterized. Typical similar equipment is at 15,000 ft.

**Humidity (Operating/Storage):** 5% to 95% non-condensing.

**Vibration:** Not specified or characterized

**Shock:** Not specified or characterized

**MTBF:** Available upon request

**Weight:** 66 grams

**Voltages Required:** +12V, -12V, +5.0

**Power:** 0.96W@+5V, 0.22W@-12V, 0.012W@+12V

**Size:** 74mm x 143.7mm

### ORDERING INFORMATION

**4966:** 2-Port RS232/RS422/RS485 Asynchronous Serial Communications Adapter PMC

