

PMC Carrier/Adapter

64-Bit PMC to PCI Adapter for Delivery Systems

This 64-bit PMC to PCI Adapter permits delivery of PMC-derived applications in a standard PCI environment.

Mechanically, a PMC card fits cleanly on a short-length PCI board, resulting in a highly acceptable delivery solution for desktop applications. PMC suppliers can introduce products to desktop packaging without having to maintain two PCI-based designs - one for standard PCI and a second for PMC.

This product has been specifically designed to improve PCI bus signal integrity while still retaining the convenience of a passive adapter. The key control signals on the PCI bus (IRDY, TRDY, FRAME, etc.) are Schottky-diode clamped to ground in order to reduce signal undershoot.

The 32-bit PCI bus (AD[31..0]) has 10 ohm series termination which reduces undershoot/overshoot on the address/data lines. Because the distance from the 64-bit PCI databus

(AD[63..32]) to the corresponding PMC connector (PN3) is minimal, a direct connection from the edge finger to the AD[63..32] is implemented for these signals.

A 3.3V linear regulator on the board converts the 5V power from the PCI edge finger to 3.3V to the PMC. This allows operation in motherboards which do not support 3.3V power. The maximum current from the regulator is 3 Amps.

Several LEDs visible from the edge of the board monitor power (VIO, +12V, -12V, 5V, 3.3V) and key PCI bus signals (INTx, BUSMODE1, REQ32). One LED senses the VIO signal voltage to indicate if the slot uses 3.3V (VIO = 3.3V) or 5V (VIO = 5V) PCI bus signaling.

A fan on the adapter, under the central area of the PMC card, is provided to effectively cool higher-powered PMC cards. The dimensions and positioning of the fan adheres to the IEEE 1386 component height restrictions, allowing use of any IEEE 1386



4954

- Adapts PMC Card to PCI Slot
- Embedded Fan Provides Direct Cooling for PMC
- Supports 3.3V PMC on 5V Host
- DIN Connector Allows Access to Rear I/O Signals
- JTAG Interface for Test & Programming
- LEDs Indicate Status of Key PCI Signals & Power
- RoHS-compatible
- Lead-free

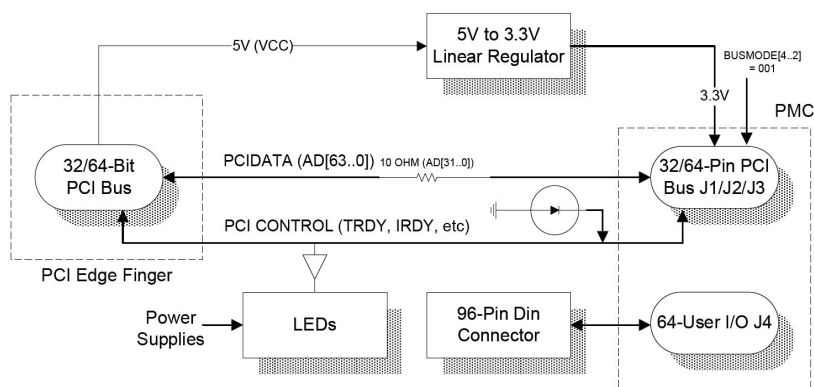

Technobox[®], inc.

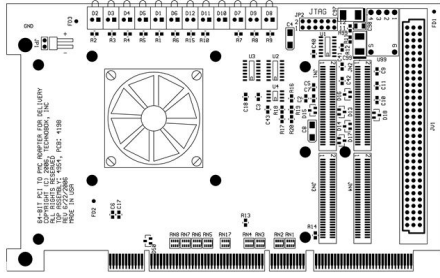

COMPONENT PLACEMENT VIEW - SIDE #1

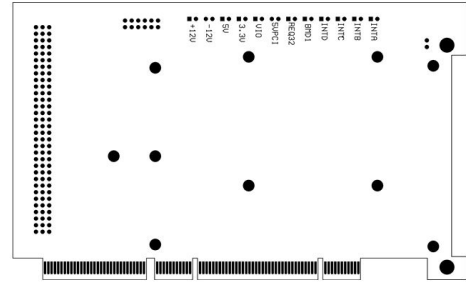

COMPONENT PLACEMENT VIEW - SIDE #2

compliant PMC in the adapter. The BUSMODE[4..2] to the PMC is set for the PMC encoding (001).

The JTAG signals between the PCI bus and the PMC are intercepted with a header. This allows either jumpers to be installed to connect JTAG on the PMC to the PCI bus, or access to the JTAG signals to permit testing and programming of the user's PMC circuits.

The A and C rows of a 96-pin DIN connector, located toward the rear of the board, connect with the 64-pin user I/O connector (J4/P4) on the mezzanine card. This connection is specified by IEEE 1386 for the P2 connector on VMEbus boards and permits internal connection of rear I/O, should the PMC board support rear I/O connectivity.

A high quality 2.5 mm thick machined aluminum panel, with a 0.5

mm chamfered edge, is provided on the PCI board bracket. This mimics the mechanics of a PMC installed on a VMEbus board or other host environments, and allows the PMC bezel to be firmly positioned on the board.

SPECIFICATIONS

Temperature (Operating): -10 to +70 degrees C

Temperature (Storage): -40 to +85 degrees C

Altitude: Not Specified or Characterized. Typical similar equipment is at 15,000 ft.

Humidity (Operating/Storage): 5% to 95% non-condensing.

Vibration: Not specified or characterized

PCI Environment: 3.3V, 5V; 32- or 64-bits/33MHz PCI Bus

ORDERING INFORMATION

4954: 64-Bit PMC-to-PCI Adapter for delivery

