

PMC Carrier/Adapter

PMC to PCI Express Adapter

The 4733 and 4749 carrier cards allow use of a PMC in a PCI express edge card slot. The product features a Broadcom* PEX8114 bridge IC used in transparent mode with a PCI express primary side and a PCI/PCI-X secondary side. The 1 lane Technobox P/N 4749 fits in 1, 4, 8 and 16 lane PCI Express slots. The 4 lane Technobox P/N 4733 fits in 4, 8 and 16 lane PCI Express slots.

The primary side of the PEX8114 bridge is a generation 1 PCI express interface running at 2.5 Giga bits per seconds per lane in each direction. Each lane is composed of a 2.5GHz transmit and a 2.5GHz receive differential pair.

The PCI/PCI-X secondary side operates at 33, 50, 66, 100 or 133 MHz in 64- or 32-bit bus width mode.

For rear I/O applications the 64 users rear I/O signals on the PMC PN4 connector are available at the A and C rows of a 96-pin DIN

connector. An optional fan assembly (P/N 4936) is available that fits over two PMC-to-PCI express adapter boards and provides substantial forced-air cooling of high-power PMC modules.

This bridged adapter needs no additional software support since PCI Express is backward compatible with PCI software. Software support for the PMC in use is provided by the PMC supplier.

This product should only be used with or 3V/5V PCI signaling PMC cards. Use of 5V PMC cards is prevented by voltage keying.

Several activity LEDs give an indication of key PCI and PCI express signals and voltages.

The XCAP and M66EN signals are supported by DIP switch settings to force operation at non-X or lower PCI clock frequencies. The JTAG signals from the PMC PCI bus and



4733

- Adapts a PMC or PMC-X to a PCIe Site
- PLX 8114 Bridge
- 2.5 Gb/s per Lane (Each Direction)
- LEDs for Key PCI & PCIe Signals & Voltages
- Optional fan assembly for additional cooling
- RoHS-compatible
- Lead-free

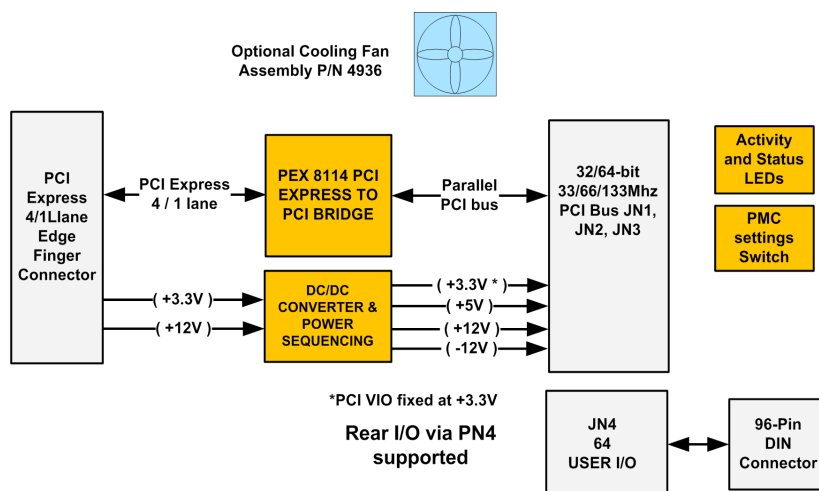

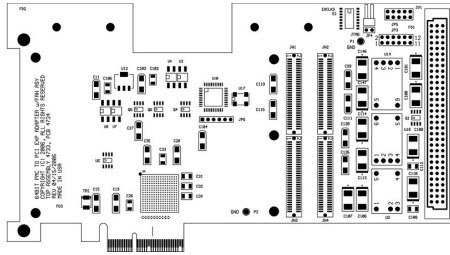

COMPONENT PLACEMENT VIEW - SIDE #1

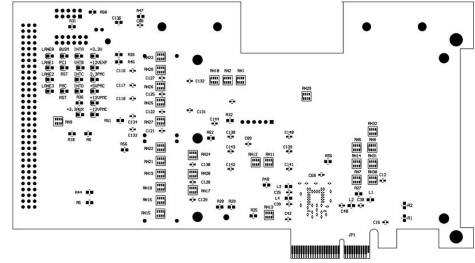

COMPONENT PLACEMENT VIEW - SIDE #2

the PCI express bus are brought out to headers allowing users the option of connecting the JTAG ports.

This board has been carefully designed to minimize signal lengths on the 2.5GHz LVDS PCI Express bus. Four impedance-controlled signal layers and four power planes (2xGND, 3.3V, and V1.0) are employed to minimize transmission line effects.

A high quality 2.5 mm thick machined aluminum panel, with a 0.5 mm chamfered edge, is

provided on the PCI board bracket. This mimic the mechanics of a PMC installed on a VMEbus board or other host environments and allows the PMC bezel to be firmly positioned on the board.

The following sections describe these features in more detail.

CAUTION: It is important to make sure the signaling environment of the PMC card is 3.3V, or dual 5V/3.3V as this adapter card is 3.3V only. The mechanical key should not be removed as this prevents

insertion of 5V PMC cards. FOR 5V ONLY PMC CARDS CONSIDER using Technobox P/N 5243.

*Broadcom is the current producer of the PEX8114, it was originally made by PLX which was acquired.

SPECIFICATIONS

Temperature (Operating): -40 to +85 degrees C

Temperature (Storage): -55 to +100 degrees C

Altitude: Not Specified or Characterized. Typical similar equipment is at 15,000 ft.

Humidity (Operating/Storage): 5% to 95% non-condensing.

Vibration: Not specified or characterized

MTBF: Available on request

Typical Power Dissipation: Per PMC under test

PCI Environment: 3.3V, PCI-X 32/64 bit, 33/66/100/133 MHz

ORDERING INFORMATION

4733: PMC to PCI Express Adapter - 4 Lane

4749: PMC to PCI Express Adapter - 1 Lane

4936: Optional Fan Assembly

