

# Digital I/O PMC

## Enhanced 32-Channel RS485/422 Differential PMC

The Enhanced 32-channel Reconfigurable RS422/RS485 Digital I/O PMC provides a vehicle for implementing complex user-specific digital designs requiring a differential interface.

This product is a second-generation "enhanced" design derived from the P/N 2674/3353 products, and provides additional features including 64b/66MHz PCI bus support, up to 66 MHz local bus clock, double the local SRAM, and up to 20K Logic Elements compared to 3.7K LEs on the original 10K70 based design. All the features of the 2674/3353 boards have been incorporated into this new product, enabling customers easy migration for existing applications.

The product uses an Altera "Cyclone" FPGA in a 324 Fine-Line FPGA. This package spans the 4K, 12K, and 20K logic element parts. The standard, stocked product uses an EP1C12F324C8 density/speed part.

The design features a total of 32 general-purpose RS422/RS485

driven digital I/Os wired to both the front panel and rear PN4 connector (64 signals per connector taking into account 2 signals per differential pair). For each of the 32 channels, the bidirectionality is controlled by an output from the FPGA.

The 68-pin front panel connector is compatible with standard fast/wide differential SCSI cables. Furthermore, an optional Technobox transition panel (e.g., P/N 3044) may be used to break out the differential signals into more convenient individual connectors, such as DB9s.

Each of the 32 differential pairs is terminated with a 120 ohm parallel resistance or an R/C termination as shown in the block diagram. Individual resistors are used with each differential pair, allowing for easy removal or value change on a per-channel basis.

With the proper FPGA design the 256K x 32b SRAM provided on the PMC is accessible from the Altera part as well as the PCI interface. The

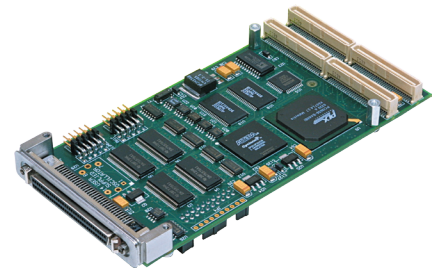

**4289**  
.....

- Provides 32 Channels of General-purpose RS485/422 Digital I/O
- Supports 64 bit / 66 MHz PCI Bus
- 12K Logic Elements (4289 Populated with Altera EP1C12F324C8); Other Densities as Production Build Options
- Reprogrammable by Host, On-board Flash or ByteBlaster Cable
- Local Bus SRAM (256K x 32bit)
- Optional Header for Attaching a Logic Analyzer
- Sample FPGA Design and Host "C" Code

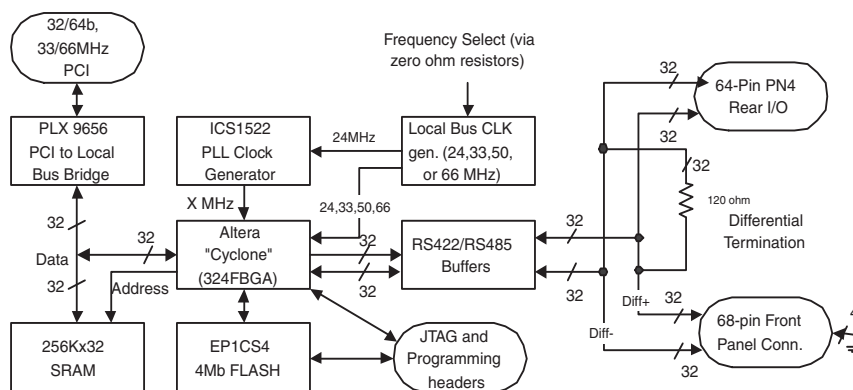

**Technobox**

